

C101

Pump/Valve

Service Instructions
HS20

®  **Commercial**
Intertech

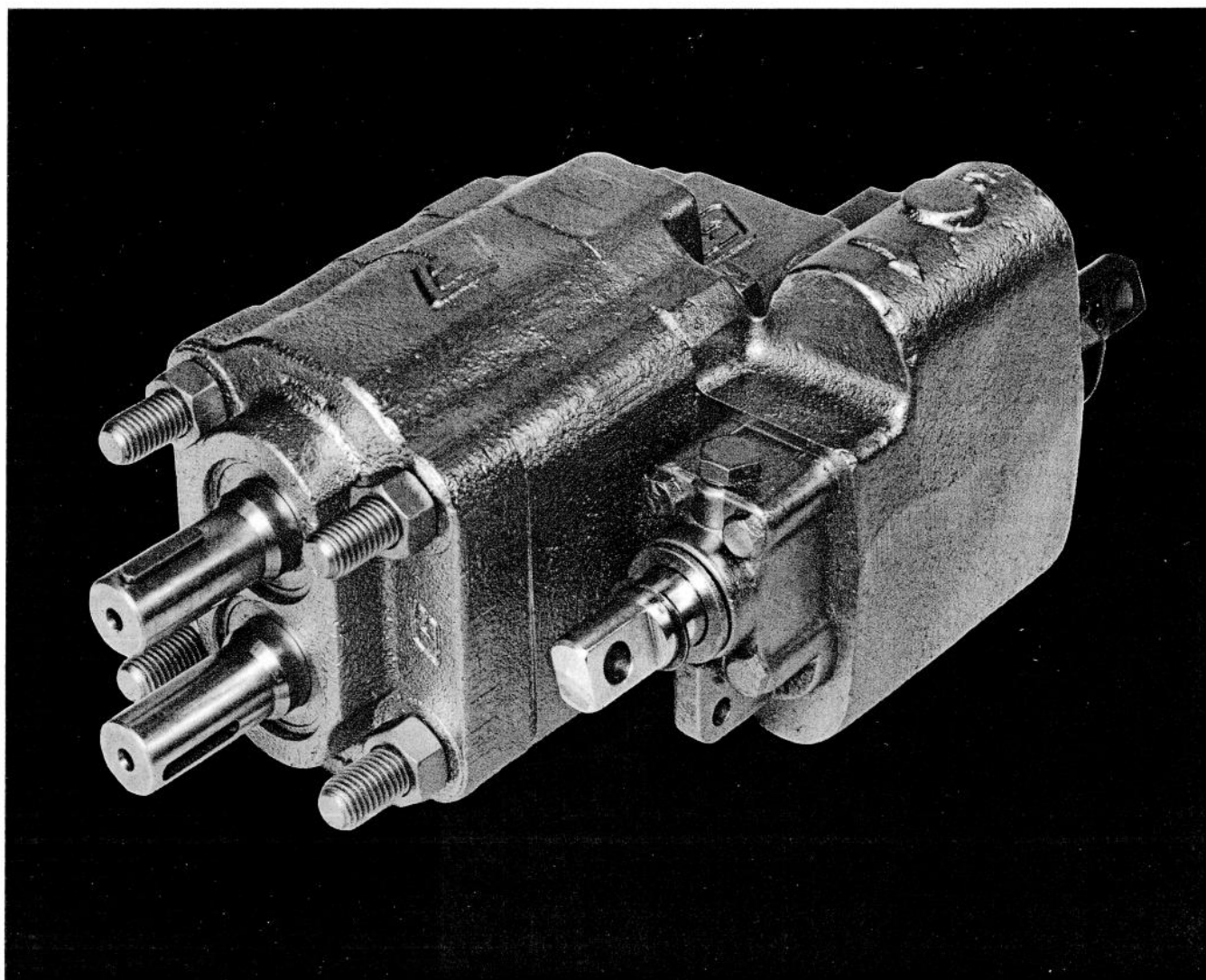

contents:

- Cleanliness 1
- Options 1
- Lubrication and Oil
 - Recommendations 2
- Recommended Start-up Procedure for new or rebuilt pump or motor 3
- Tool List 3
- Disassembly 4
- Parts List 5
- Combination Relief Valve-Check Valve 5
- Assembly 6
- C101 Relief Valve Maintenance ... 7
- C101 Relief Valve Adjustment 7
- C101 Service Kits 8
- Troubleshooting 9

introduction

The C101™ pump/valve is designed to give long, trouble-free operation at 2000 psi. Flows at 1800 rpm range up to 38 gpm for 2" models and 48 gpm for 2 1/2" models. Operating pressures should not exceed 2000 psi without application approval from Commercial's product support department.

cleanliness

The most common cause of premature pump failure is dirty oil. Modern hydraulic components require very close tolerances to operate efficiently at high pressures. Contaminants, no matter how small, cause wear and decrease the life of the piece of equipment. Make sure all components are clean when they're installed and that regular maintenance practices keep the oil clean.

options

two line installation

Generally used for long haul, intermittent operation. When the

spool is in neutral, the unit will circulate oil internally. Two lines are used, one line to cylinder and one to tank. **The PTO must be disengaged during travel.**

three line installation

This circuit is recommended for short hauls where the unit is in nearly continuous operation. With the spool in neutral, oil circulates through the unit and returns to tank. Three lines are used, one line to cylinder, one intake line and one return line.

This configuration requires installation of a sleeve in the pump's inlet. (P/N) 391-3283-052)

warning

C101 pump/valves should be equipped with a lockable control lever to prevent the unit from accidentally being shifted from the neutral position during travel. Failure to install such a lock may allow the dump bed to raise unintentionally which can lead to injury and/or damage to the vehicle.

Lubrication and oil recommendations

All parts are lubricated by the hydraulic oil in the circuit. Particular attention must be paid to keep the oil in the system clean. Whenever there is a pump failure and there is reason to feel that metal particles may be in the system, the oil must be drained, the entire system flushed clean and any filter screens thoroughly cleaned or replaced. New oil should be supplied for the entire system. Oil suitable and recommended for use in circuits involving Commercial's pumps and motors should meet the following specifications.

viscosity:

- 50 SSU minimum @ operating temperature
- 7500 SSU maximum @ starting temperature
- 150 to 225 SSU @ 100°F (37.8°C) (generally)
- 44 to 48 SSU @ 210°F (98.9°C) (generally)

approximate SSU at...

Oil Grade	100°F (37.8°C)	21°F (98.9°C)
SAE10	150	43
SAE20	330	51

SAE10	150	43
SAE20	330	51

viscosity Index: 90 minimum
aniline Point: +175° (80°C) minimum

recommended additives:

Foam Depressant
Rust and Oxidation Inhibitors

other desirable characteristics:

- Stability of physical and chemical characteristics.
- High demulsibility (low emulsibility) for separation of water, air and contaminants.
- Resistant to the formation of gums, sludges, acids, tars and varnishes.
- High lubricity and film strength.

general recommendations:

A good quality hydraulic oil conforming to the characteristics listed above is essential to satisfactory performance and long life of any hydraulic system.

Oil should be changed on regular schedules in accordance with the manufacturer's recommendations and the system periodically flushed.

Oil temperature in reservoir must not exceed 200°F (93.3°C) with a maximum temperature of 180°F (82.2°C) recommended. Higher temperatures will result in rapid oil deterioration.

Reservoir capacity should equal that of the cylinder(s) plus 20 gallons or be approximately 1 1/2 times the output of the pump.

Oil poured into the reservoir should pass through a 100 mesh screen. Pour only clean oil from clean containers into the reservoir. A 100 mesh screen may be used in the suction line leading to the pump. A suction filter should be of sufficient size to handle twice the pump capacity. It must be cleaned and checked regularly to avoid damage due to contamination and cavitation.

Always mount the pump lower than the hydraulic reservoir to insure the inlet will be flooded with a good supply of oil.

normal temperatures:

- Ambient.
- 0°F (-18°C) to 100°F (37.8°C) System.
- 100°F (37.8°C) to 180°F (82.2°C)

Be sure your oil is recommended for the temperatures you expect to encounter.

cold weather operations:

Oils for use in cold weather should have a viscosity not exceeding 7500 SSU at the minimum start-up temperature. A pour point of at least 20°F below start-up temperature is recommended. Start-up procedures should allow for a gradual warm-up until the oil reaches a reasonably fluid state.

the use of other oils:

- Automatic Transmission Fluid (ATF): General experience here has been satisfactory; however, ATF oils are sometimes too expensive for normal use in hydraulic systems.
- Diesel Fuel or Kerosene (Coal Oil): Sometimes used as dilutants for cold weather operations but are not recommended as they are not sufficiently refined products.
- Fire Resistant Fluids: Of the several different types, only the inverted emulsion types may be used without changing to special seals, packaging, gaskets, hose, etc., compositions. Their use may materially reduce pump life. Experience indicates that the use of FR fluids can be disastrous unless certain precautions are followed. **DO NOT USE ANY FIRE RESISTANT FLUIDS OR NON-PETROLEUM OILS WITHOUT CONSULTING OUR PRODUCT SUPPORT DEPARTMENT.**

- These suggestions are intended as a guide only. **OBTAIN YOUR FINAL OIL RECOMMENDATIONS FROM YOUR OIL SUPPLIER.**

recommended start-up procedure for new or rebuilt pump or motor

Before installing a rebuilt pump, back-off the main relief valve until the spring tension on the adjusting screw is relieved. This will avoid the possibility of immediate damage to the replacement unit in the event that the relief valve setting had been altered.

Before connecting any lines to the pump pour a small quantity of clean oil in the inlet port to provide initial lubrication.

After connecting the lines and mounting the replacement unit, operate the pump at least two minutes at zero pressure at lowest possible rpm. During this break-in period, the unit should run free and not develop an excessive amount of heat. If the unit operates properly, speed and pressure can then be increased to normal operating setting of 2000 psi.

Reset the main relief valve to its proper setting while the pump is running at maximum operating engine speed for the vehicle.

ALWAYS USE AN ACCURATE GAGE WHEN ADJUSTING THE RELIEF VALVE PRESSURE SETTING.

tool list

- Arbor Press
- Bearing Puller (Owatonna Tool Co. MD-956 or equivalent)
- Clean Lintless Cloths
- Deburring Tool (an old file with the cutting teeth ground off)
- Machinist's Hammer
- Soft Hammer
- Permatex Aviation Form-A-Gasket No. 3 Non-hardening Sealant or Equivalent
- Medium Grit Carborundum Stone
- Oil and Grease
- Snap Ring Pliers
- Prick Punch
- Sharp Razor Blade
- Scale (1/32" or 1/64" graduations)
- Small Screwdriver
- Torque Wrench
- Vise with 6" Minimum Open Spread
- Bar for Lip Seal Installation (use 21/8" dia. by 2" bar)
- Special Steel Sleeve

A seal remover tool can be easily made from an old screwdriver. Heat the blade and bend the tip as shown. Grind the tip to fit the notch behind the shaft seal.

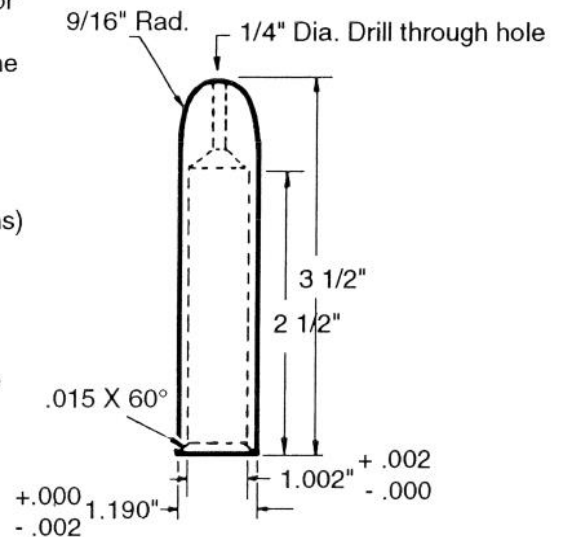
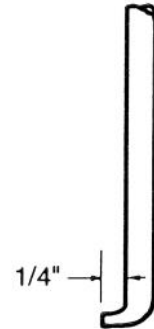

All external surfaces must be free of scratches and burrs.

The special steel sleeve is used to insert the drive shaft through the lip seal without damage and can be made from bar stock. The drawing and chart give details for making this tool.

disassembly

1. Wash and wipe all dirt from the outside of the unit. Mark castings to simplify reassembly. Remove the key(s) from the drive shafts and save for remounting.

2. If unit has a mounting bracket attached, take it off by removing the four hex nuts and washers.

3. Grip the valve end of the pump in a large vise so the drive shafts are exposed. Remove the snap ring from each drive shaft bore in the shaft end cover.

4. Turn the unit end-for-end and grip the shaft end cover in the vise.

Note: *If the spool or relief valve is not to be removed, proceed to item 7. Be sure that the valve spool shifts freely in bore and that the detent holds.

5. Remove relief valve cartridge from valve assembly. (Relief valve maintenance instructions are given on page 7.) Keep all dirt and foreign material out of the open, working end of relief valve.

6. If spool "O" rings are to be replaced, the valve spool must be removed from the valve housing.

a. With spool in neutral position, remove the detent retainer, spring and detent ball from valve cap (pen magnet works well to remove detent ball). Be careful not to lose spring.

b. Remove the snap ring and retainer ring on the front of the spool.

c. Remove the four bolts holding the valve cap and slide it off the spool.

d. Remove the two socket head cap screws holding the spool end cap bracket and slide it over the end

cap. Remove the spiral pin from the spool and slide off the end cap.

e. Remove dirt and paint from spool.

f. Push spool through the bore to determine if it slides freely. Remove it from bore.

If the spool drags in the bore, inspect the spool for nicks or burrs. If possible, remove these with 330 or finer emery or crocus cloth.

If the spool continues to drag, it may be bent or the spool bore may be damaged. Spools are hone-fitted to their individual housings. Therefore, damage to either of these components means the entire valve must be replaced.

g. Remove the "O" rings from both ends of the bore and discard. Check "O" ring groove for any foreign material.

7. Remove cap screws with a sturdy socket and breaker bar and lift the valve housing from the assembly. Remove thrust plate if it remains attached to the valve housing.

8. Push upward on the end of the drive shaft until gears can be lifted out of gear housing.

9. Using two pry tools or screwdrivers, separate the gear housing from the shaft end cover. Be careful not to damage machined surfaces. Remove the gasket seals from their grooves and discard. Remove the thrust plate from housing bore. Discard pocket seals.

10. Use a screwdriver or bent pry tool to tap the shaft seals out of their bores. Discard the seal.

11. Remove bearings from the shaft end cover and valve housing with a bearing puller. The high pressure ring seals can then be lifted out and inspected for wear.

12. Wash all component parts in solvent and blow dry prior to inspection.

component inspection

Wear on component parts will often indicate what problems existed while the unit was in operation. Listed below are major components and general rules to help you determine acceptable wear limits.

gear housing

Wear in excess of .005" cut-out necessitates replacement of the gear housing.

Place a straight-edge across bore. If you can slip a .005" feeler gage under the straight edge in the cut-out area, replace the gear housing.

Pressure pushes the gears against the housing on the low pressure side. As the hubs and bearings wear, the cut-out becomes more pronounced. Excessive cut-out in a short period of time indicates excessive pressure or oil contamination.

The C101 gear housing can not be "flopped" because the high and low pressure sides are not interchangeable.

drive shafts/gears

Replace if there is excessive wear in the ring seal areas or at the drive coupling. .002" wear is the maximum allowable.

Any scoring on gear hubs detectable by touch, or wear in excess of .002" necessitates replacement. Scoring, grooving or burring of outside diameter of teeth requires replacement. Nicking, grooving or fretting of tooth surfaces also necessitates replacement.

The gears in the C101 are a matched set. Therefore, both gears must be replaced with another matched set.

bearings

If the gears are replaced, replace the bearings. Worn bearings are indicated by rollers falling out of the cage, pitting or metal flaking from the roller tips or the inside race.

Bearings should fit into the bore with a light press fit, however, a neat hand fit is allowable. If bearings do not fit snugly, the bearing bores may be worn and the casting should be replaced.

thrust plates

The thrust plates seal the oil at the sides of the gears. Wear here will allow internal slippage, that is, oil will bypass within the pump and decrease efficiency. .002" maximum wear is allowable.

Replace thrust plates if they are scored, eroded or pitted.

Check center of thrust plates where the gears mesh. Erosion here indicates oil contamination.

Pitted thrust plates indicate cavitation or oil aeration.

Discolored thrust plates indicate overheating, probably insufficient oil or traveling with PTO engaged, a dangerous practice.

seals and gaskets

Replace all rubber and polymer seals whenever repairing pump. Include all "O" rings, pocket seals behind thrust plates, shaft seals and gasket seals.

valve repairs

Repairs to the valve assembly are limited to replacing worn spool seals and relief valve maintenance detailed on page 7. No repair should be attempted on the spool

itself except the light polishing as indicated in disassembly step 6.

combination relief valve/check valve

Major wear points are the check poppet and internal poppet and seat. The relief valve can be disassembled and cleaned in solvent and blown dry. If parts are worn or the operation of the relief valve is suspect, replace the cartridge.

assembly

Always Use Genuine Commercial Intertech Replacement Parts

1. Wash all parts in solvent and blow dry.
2. Clean shaft seal bores with fine emery cloth to remove any burrs or old sealant.

Apply Permatex™ aviation form-a-gasket, #3 non-hardening sealant or equivalent to the O.D. of the seals. Press the seals into the bores with an arbor press.

Wipe off any excess sealant on the O.D. of seal.

3. If bearings were removed at disassembly, drop the high pressure ring seals in each bearing bore with flat side down.

Press bearings into their respective bores in shaft end cover and valve housing using a flat bar and arbor press. The bearings will bottom out in the casting and should protrude equally from the machined surface.

4. Place the shaft end cover in a vise with the bearings facing up. Cut two center pocket seals 7/32" long from the pocket seal strip with a razor blade and insert in the thrust plate. Use light grease to hold seals in place.

Note: The thrust plate is designed with distinct high and low pressure

sides. The off-center hole must be on the high pressure side (valve side) of housing.

Note: The rotation arrows cast in shaft end cover face must point toward the valve.

5. With the pocket seals facing down, place the thrust plate over the bearings in the shaft end cover. Tap thrust plate with a soft hammer to about 1/32" from the machined surface.

Cut four pocket seals approximately 1/4" long from the pocket seal strip. Insert one pocket seal into each of the slots in the thrust plate. Push each pocket seal all the way in so that it touches the roller bearings. Tap the thrust plate down firmly against the machined surface with a soft hammer. Use a sharp razor blade to trim exposed end of the pocket seal square and flush with the thrust plate. Repeat the procedure for the valve housing thrust plate.

6. Insert the end of the drive shaft into the steel sleeve (see Tool List). Lightly grease the drive shaft and sleeve. Insert the integral gear and drive shaft with sleeve into the shaft end cover with a twisting motion. Be careful not to damage the lip seal. Push down carefully until the gear rests against the thrust plate. Remove the steel sleeve. Insert the other gear.

7. Lightly coat the gasket seals with grease and install them in the gasket seal grooves in the gear housing. Slip the gear housing over the gears.

Note: The protrusion on one side of the gear housing must be installed on the low pressure side.

8. Seat the valve housing assembly on the gear housing. Be sure not to pinch the gasket seals. A light tapping with a soft mallet may be required.

CAUTION: Valve spool extends over the high pressure side, and opposite the protrusion on the gear housing.

9. Install the four washers on the cap screws and thread into the shaft end cover. Tighten the cap screws cross-corners to 2400 in./lb. Check for free shaft movement by turning shafts with a wrench.

10. Install the spool "O" ring into the groove in the valve at the end opposite from the detent housing. Apply a light coating of **clean** hydraulic oil to the spool. Insert the spool into the housing from the detent cap end. Be careful not to cut the "O" ring. Push the spool through the housing.

11. Apply a light coating of oil to the second spool "O" ring and install it over the spool and into its groove behind the detent retainer.

12. Attach the detent retainer with the four cap screws. It must be carefully aligned so it does not contact the spool.

13. Install the detent ball, spring, washer and retainer.

14. Install the retainer ring and snap ring on the front end of the spool.

15. Install the relief valve in the housing. Back off the adjustment screw to the lowest possible pressure setting.

16. Slip spool end cap over the rear spool clevis. Align the pin eye in the spool with the slot in the spool end cap and install the spool pin. Next install the bracket with two (2) socket head cap screws.

17. Finish assembling the C101 by installing the 3-line sleeve and mounting bracket option that fits your individual requirements.

C101 relief valve maintenance

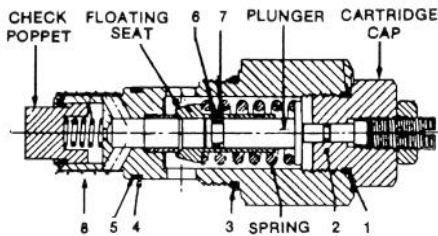

Figure 2.
Relief Valve

item	qty	description	
1	1	O-ring	391-2881-247
2	1	O-ring	391-2881-497
3	1	O-ring	391-2881-249
4	1	Back-up Ring	391-2681-324
5	1	O-ring	391-2881-461
6	1	O-ring	391-2881-727
7	1	Back-up Ring	391-2681-416
8	1	Screen	391-2781-011

Commercial's C101 pump/valve units have unique internal passages in the valve assembly that allow the relief valve to function as a main and a port relief and a load-hold check. All mechanical structures integrated with the hydraulic system are consequently protected from overload and excessive shock stresses.

Figure 2 shows the arrangement of internal parts and the location of the serviceable seals. If contamination lodges between the poppet and seat, the relief valve will leak internally and prevent the cylinder from being pressurized or allow the load to drift.

The relief valve can be cleaned without altering its pressure setting by removing the 1-3/8" hex cartridge cap. The floating seat, spring and plunger can then be removed as a subassembly. The exposed

seat area then can be cleaned by flushing with solvent and blowing with air.

The load-holding check seats on a machined face in the valve housing. The relief valve cartridge must be removed to inspect or clean the check's seat area.

If cleaning or replacing seals fails to correct relief valve problems, the cartridge should be replaced.

C101 units produced after February 1, 1983 have a tubular wire screen which fits snugly over the poppet end of the relief valve. The screen greatly reduces the possibility of contamination reaching the seat area. It is available as a service part (Part No. 391-2781-011) and can be retrofit on all C101 relief valves, (Part No. 355-9001-067).

C101 relief valve adjustment

All relief valves in these units are factory pre-set at 2000 psi. The table below has been developed to aid in the readjustment of these relief valves if it becomes necessary.

To readjust the relief valve, loosen the jam nut and turn the adjustment screw **counter-clockwise** the prescribed number of turns.

Factory pressure setting 2000 psi.

Turning Adj. Screw CCW	Results in a new pressure setting of:
1/4 turn	1800 psi
1/2 turn	1600 psi
3/4 turn	1400 psi
1 full turn	1200 psi
1-1/4 turn	1000 psi

Note: Due to normal manufacturing tolerances, the actual pressure settings obtained by readjustment may vary slightly from those shown in the table.

parts list

CAUTION;

1. Exploded view may not be pictorially correct and is not to scale.
2. Exploded view and attached bill of material will not be kept up-to-date. Refer to current engineering drawing for bill of materials.
3. All repairs should be made in accordance with Commercial's service instructions.
4. Use only genuine Commercial Intertech parts for repairs.

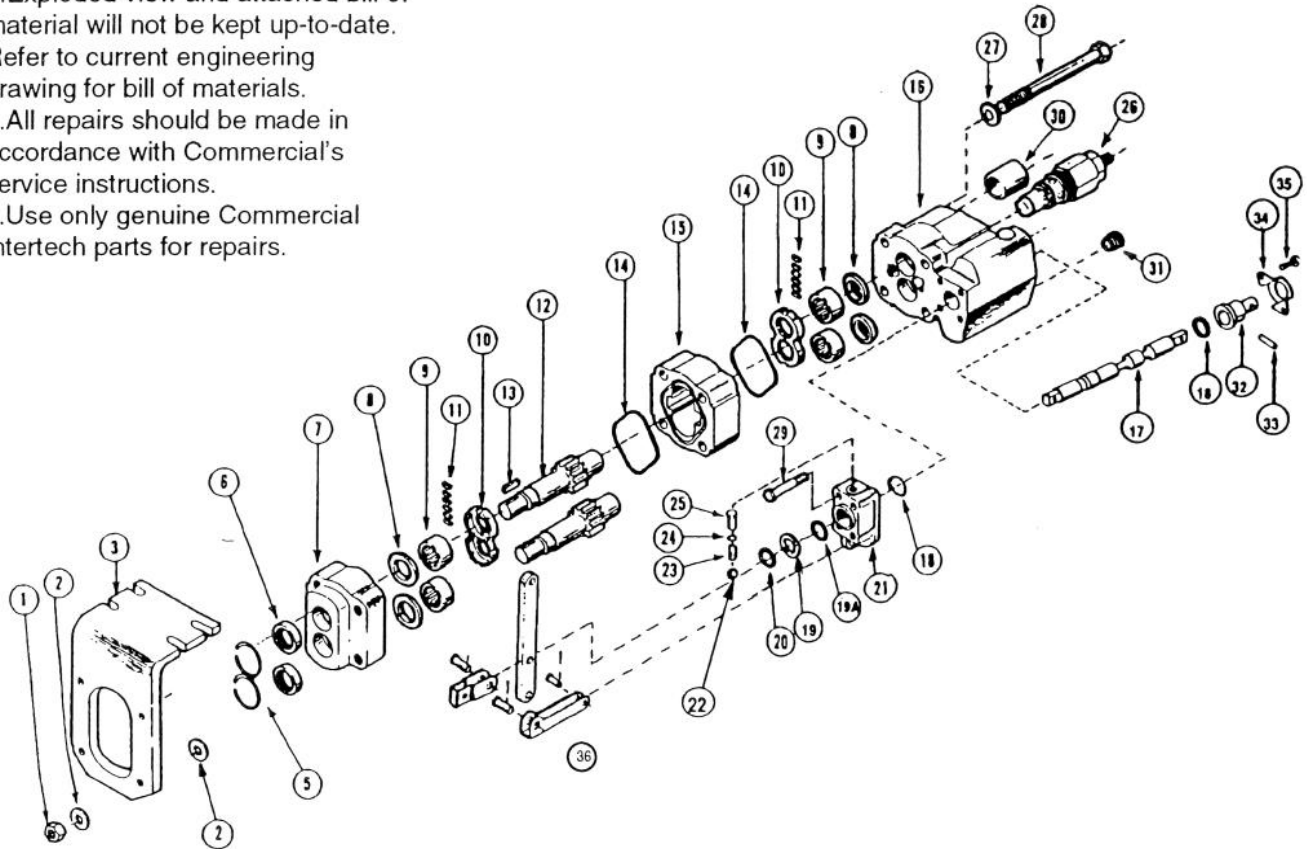

Item	Description	Part No.	Req.			
				18	"O" Ring	391-2881-103 2
				19A	Wiper Ring	391-2883-147 1
				19	Retainer Ring	391-3782-126 1
				20	Snap Ring	391-2688-003 1
1	Hex Nut	391-1451-076	4	21	Detent Cap	314-0100-003 1
2	Washer	391-3784-028	8	22	Detent Ball	391-0282-009 1
3	Bracket (optional)	314-0100-005	1	23	Detent Spring	391-3581-383 1
5	Snap Ring	391-2681-493	2	24	Lock Washer	391-3788-002 1
6	Lip Seal	391-2883-096	2	25	Detent Retainer	391-2583-079 1
7	Shaft End Cover	314-5039-201	1	26	Relief Valve	355-9001-067 1
8	Ring Seal	391-2585-009	4	27	Washer	391-3784-029 4
9	Roller Bearing	391-0381-059	4	28	Cap Screw 2" units	391-1401-111 4
10	Thrust Plate	391-2185-016	2		2-1/2" units	391-1401-110 4
11	Pocket Seals	391-2882-050	12	29	Cap Screw	391-1401-082 4
12	Gear Set 2" gears	314-2920-640	1	30	Sleeve	391-3283-052 1
	2-1/2" gears	314-2925-640	1	31	Pipe Plug-1" NPT	391-2282-006 1
13	Shaft Key	391-1781-021	1	32	Spool End Cap	391-1881-073 1
14	Gasket Seal	392-2884-021	2	33	Spiral Pin	391-2085-009 1
15	Gear Housing			34	Bracket	391-0981-010 1
	2" gear	314-8020-100	1	35	Skt Hd. Cap Screw	391-1402-063 2
	2-1/2" gear	314-8025-100	1	36	Handle Ass'y. (opt)	355-9100-009 1
*16	Port End Cover		1			
*17	Valve Spool		1			

*Items 16 and 17 are not serviceable parts.

C101 service kits

neutral stop device (pre 1988)

Shaft seal service kits and repair kits are available for the C101 pump/valves. Parts included in these kits are shown below. Refer to exploded drawing on page 7 for location of parts.

Seal Kit J300-11 391-1802-157

Item	Qty	Descript.	Part No.
6	2	Shaft Seal	391-2883-096
-	1	Seal Installing Sleeve	391-4022-002

Repair Kit 391-1802- 221

Item	Qty	Descript.	Part No.
20	2	Snap Ring	391-2688-003
19	2	Retainer Ring	391-3782-126
18	2	'O' Ring	391-2881-103
8	4	Shaft Ring Seals	391-2585-009
11	1	Pocket Seal Strip	391-2882-051
14	2	Gasket Seal	391-2884-021
10	2	Thrust Plate	391-2185-916
6	2	Shaft Seal	391-2883-096
-	1	Seal Installing Sleeve	391-4022-002

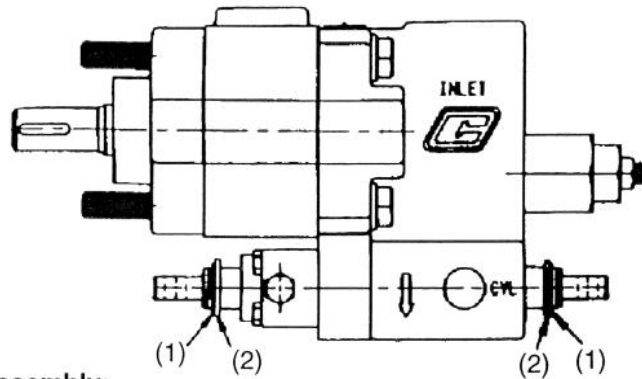

Disassembly:

Remove snap rings (1) and washers (2) from both ends of the valve spool.

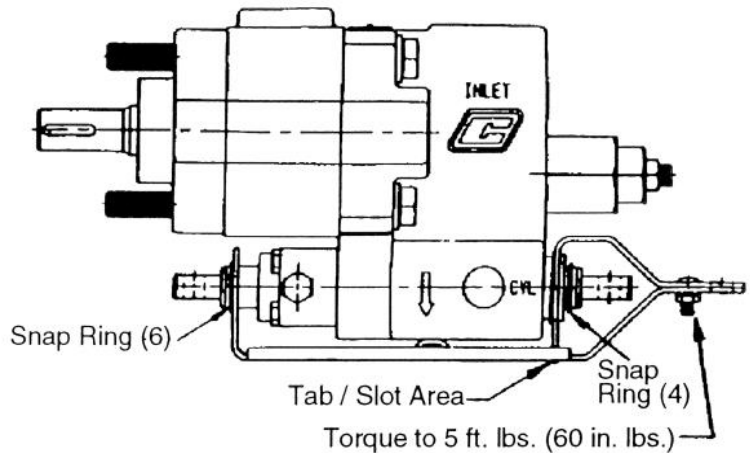

Assembly:

- Slide the shortest bracket assembly (3) over the rear end of the valve spool and install snap ring (4) onto the spool.
- Slide the longer bracket (5) over the front of the spool and install snap ring (6) on the spool.
- Slide tab on bracket (3) through slot in bracket (5).
- Bolt brackets together with carriage bolt (7), washer (8) and nut (9).

Neutral Stop Components (pre-1988)

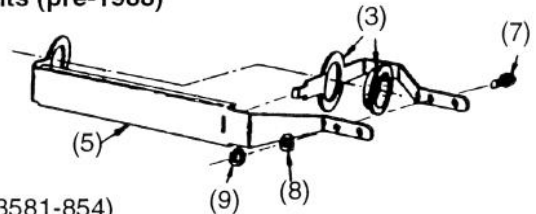

Cable Spring (P/N 391-3581-854)

A spring, attached to the dump

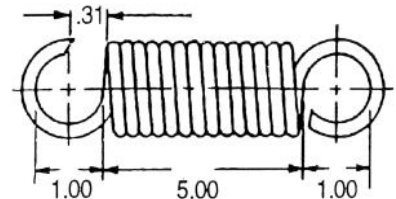

trouble	improper operation of pump/valve unit	
	possible causes	remedies
Pump Making Noises	Insufficient oil supply	Check reservoir oil level. Fill as required.
	Air leaks at inlet fittings	Tighten as required.
	Restricted or collapsed inlet hose	Remove and inspect. Remove blockage or replace hose as required.
	Plugged reservoir air vent	Clean or replace breather.
	Oil too thick	Change to lower viscosity.
	Air bubbles in the oil or air drawn in through inlet pipe opening	Be sure suction and return lines are well submerged in the reservoir.
Pump Overheating	Insufficient oil supply	Check reservoir oil level. Fill as required.
	Roading with PTO engaged	Disengage pump PTO when traveling.
	Internal leak due to wear	Rebuild pump as required. Check oil cleanliness, replace if dirty.
	Oil too thick	Change to lower viscosity.
	Leaking relief valve	Check for wear or contaminant in seat.
Pump Leaks Externally	Worn drive shaft due to abrasive material in the oil	Rebuild pump as required. Clean reservoir and replace oil.
	Worn shaft seal	Replace seals
	Blown or pinched gasket seal	Replace seal. Check torque on tie bolts (2400 in./lbs.)
	Worn or damaged spool seal	Replace seal.
Pump Won't Deliver Fluid	Insufficient oil supply	Check reservoir oil level. Fill as required.
	Blocked or collapsed suction line	Remove and inspect. Replace or remove blockage as required.
	Wrong drive shaft rotation	Check rotation against indicator at front of pump.
	Air leak in suction line preventing priming	Eliminate leak.
	Pump worn due to abrasive material in the oil	Rebuild pump as required. Clean reservoir and replace oil.
No Pressure in the System	Pump not delivering fluid	Follow remedies in the failure to deliver section.
	Relief valve set too low	Check pressure, increase if required.
	Relief valve leaking	Check seat for foreign material or damage. Replace if required.
Failure to Hold a Load	Valve spool not in the neutral-hold position	Check linkage and adjust.
	Foreign material lodged in the holding check or in the relief valve seat	Remove relief valve and clean it out.