

D25

SECTIONAL VALVE



TECHNICAL CATALOGUE

A member of



 **walvoil**
FLUID POWER E| MOTION

1st edition D25.05

*This catalogue shows the product in the most standard configurations.
Please contact our Sales Dpt. for more detailed information or special requests.*

WARNING!

*All specifications of this catalogue refer to the standard product at this date.
Walvoil, oriented to a continuous improvement, reserves the right to
discontinue, modify or revise the specifications, without notice.*

**WALVOIL IS NOT RESPONSIBLE FOR ANY DAMAGE CAUSED BY AN
INCORRECT USE OF THE PRODUCT.**



Applications

The valve is available with manual and hydraulic remote controls.
Working sections have auxiliary valves and a broad range of interchangeable spools.
Suitable for applications including Wheel loaders, Truck cranes, Sea platform cranes, Drilling machines, Presses.





QUICK REFERENCE GUIDE

GENERAL SPECIFICATION	D9	D3M	DVS10	D4	D6	D16	D12	DVS20	D20	D25	D40
Working sections number	1-12	1-12	1-12	1-12	1-12	1-12	1-12	1-12	1-12	1-12	1-10
CIRCUIT											
Parallel	•	•	•	•	•	•	•	•	•	•	•
Series	•	•	•	•	•	•	•		•	•	
Tandem	•	•	•	•	•	•		•	•		
Parallel circuit stroke (mm)	6	5	6	6	7	7	9,5	9,5	9,5	12	15
Series circuit stroke (mm)	6	5	6	6	5	7	6,5		6,5	8,5	
Float spool extra stroke (mm)	5	5	5	5,5	6	7	7	7	7	9,5	10
Spools pitch (mm)	31	38	35	40	46	46	56	56	64	75	91
RATED FLOW											
Max recommended flow rate (l/min)	35	55	45	80	100	150	180	250	250	380	700
Max recommended flow rate (GPM)	10	15	12	22	27	40	48	67	67	100	185
RATED PRESSURE											
Max working pressure (bar)	350	350	350	350	350	350	350	250	350	350	350
Max working pressure (PSI)	5000	5000	5000	5000	5000	5000	5000	4000	5000	5000	5000

OPTION CHART	D9	D3M	DVS10	D4	D6	D16	D12	DVS20	D20	D25	D40
Direct acting pressure relief valve	•	•	•	•							
Pilot operated pressure relief valve		•		•	•	•	•	•	•	•	•
2 stage pilot operated relief valve		•		•	•	•	•		•	•	•
Externally piloted valve	•	•	•	•	•	•	•		•	•	•
Solenoid dump valve (12 Vdc)	•	•	•	•	•	•	•				
Solenoid dump valve (24 Vdc)	•	•	•	•	•	•	•				
Main anticavitation check valve		•		•	•	•	•	•	•	•	•
Clamping valve		•	•	•							
SPOOL ACTUATION											
Manual control	•	•	•	•	•	•	•	•	•	•	•
Without lever	•	•	•	•	•	•	•	•	•	•	•
90° joystick control		•	•	•	•	•					
Hydraulic control	•	•	•	•	•	•	•	•	•	•	•
Direct electric control (12-24 Vdc)		•		•							
SPOOL RETURN ACTION											
Spring return	•	•	•	•	•	•	•	•	•	•	•
Detent in A - in B - in A/B	•	•	•	•	•	•	•	•	•	•	•
Detent in 4 th position	•	•	•	•	•	•	•	•	•	•	•
Arrangement for dual control	•	•		•	•	•	•		•		
Hydraulic load limit	•	•		•	•	•					
Pneumatic control ON - OFF		•	•	•	•	•	•	•	•		
Proportional pneumatic control		•	•	•	•	•	•	•	•		
Electrical load limit	•	•		•	•	•					
Electrohydraulic control ON-OFF (12-24 Vdc)		•	•	•	•	•	•	•	•		
Electrohydraulic control PROP. (12-24 Vdc)		•	•	•	•	•	•	•	•		
Electropneumatic control (12-24 Vdc)		•	•	•	•	•	•		•		
AUXILIARY VALVES											
Antishock valve	•	•	•	•	•	•	•	•	•	•	•
Anticavitation valve	•	•	•	•	•	•	•	•	•	•	•
Combined valve	•	•	•		•	•	•		•	•	•
Pilot combined valve						•		•	•	•	•



GENERAL INDEX

4	General specifications Standard working conditions Fluid options
5	Order example Standard thread Thread codes Tie-rod kit classification Painting
7	Dimensions
8	Typical curves Pressure drop (P - T) Pressure drop (P - A/B) Pressure drop (A/B - T) Direct relief valve curve Pilot Combined valve curve Anticavitation check valve curve
10	Inlet Section Order example Inlet side classification Valve identification Valve arrangement Inlet position and available thread type
13	Working section Order example Spool identification Spool actuation classification for manual control Spool actuation classification for hydraulic control Spool return action classification - Spring load values Work section identification Auxiliary valves identification
20	Intermediate inlet section Order example Intermediate inlet section classification Valve identification on intermediate inlet section Valve arrangement on intermediate inlet section Inlet position and available thread type
23	Intermediate outlet section Order example Intermediate outlet section classification Inlet position and available thread type (for BF intermediate) Inlet position and available thread type (for BG intermediate)
25	Outlet section (version 1 outlet) Order example
25	Outlet section (HPCO version outlet) Order example - HPCO version outlet Outlet with single tank classification Outlet with two tanks classification Carry-over connection (HPCO)
29	D25 Spare parts list Gasket kits
33	Installation
35	General conditions and patents



GENERAL SPECIFICATIONS

Standard working conditions

Description	Value
Ambient operating temperature range	-40°C / +60°C
Kinematic viscosity range	10 ÷ 300 cSt
Max contamination level	9 (NAS 1638) - 20/18/15 (ISO 4406:1999)
Recommended filtration level	b10 > 75 (ISO 16889:2008)
Internal filter (on electroproportional valves pilot line)	30 µm

All information and diagrams in this catalogue refer to a mineral base oil VG46 at 50°C temperature (32 cSt kinematic viscosity)

Fluid options

Types of fluid (according to ISO 6743/4) Oil and Solutions	Temperature (°C)		Compatible gasket
	min	max	
Mineral Oil HL, HM (or HLP acc. to DIN 51524)	-25	+80	NBR
Oil in water emulsions HFA	+5	+55	NBR
Water in oil emulsions HFB	+5	+55	NBR
Polyglycol-based aqueous solution HFC	-10	+60	NBR

For special applications and different fluids, please call our Technical Department.



ORDER EXAMPLE

D25/1: IR 009 150 A G07 W001A H006 RP G07 01 PA 100 01 PB 100 TJ A G08

TYPE:

D25: product type
/1: working section number

1) INLET ARRANGEMENT: pag. 10

IR 009 inlet side and valve type
150 setting (bar)
A G07 inlet position and available thread type

2) WORK SECTION ARRANGEMENT: pag. 14

W001A spool type
H006 spool actuation type
RP G07 type and thread section
01 PA 100 auxiliary valve (port A)
01 PB 100 auxiliary valve (port B)

3) OUTLET ARRANGEMENT: pag. 28

TJ outlet type
A G08 outlet position and available thread type

Ordering row 2 must be repeated for every work section

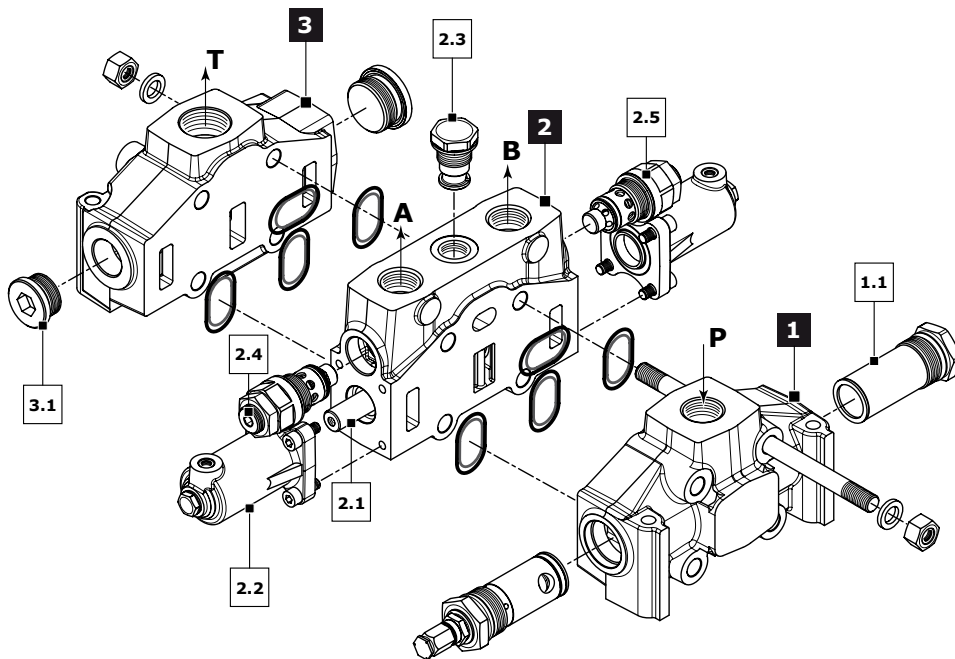

Standard thread

The connection ports size is indicated by an ordering code common for all Hydrocontrol products. Following table shows all available connections; for ordering code refer to table on page xx.

ports	BSP (ISO-228)	UN-UNF (ISO-725)	SAE 3000 (ISO 6162-1)	SAE 6000 (ISO 6162-6)
Inlet Port (P)	G 1"1/4 - G 1"1/2 G07-G08	1"5/8 - 12 UNF U07	1"1/4 MA - 1"1/4 UNC S07-S08	1" MA - 1" UNC S35-S36
Ports (A - B)	G 1"1/4 - G 1"1/2 G07-G08	1"5/8 - 12 UNF U07	1"1/4 MA - 1"1/4 UNC S07-S08	1" MA - 1" UNC S35-S36
Outlet (T)	G 1"1/2 G08	1"5/8 - 12 UNF U07	1"1/2 MA - 1"1/2 UNC S09-S10	-
Carry over (HPCO)	G 1"1/2 G08	1"5/8 - 12 UNF U07	1"1/2 MA - 1"1/2 UNC S09-S10	1"1/4 MA - 1"1/4 UNC S37-S38
Hydraulic Pilot	G 1/4 G02	9/16" - 18 UNF U02	-	-
Pneumatic Pilot	G 1/8	NPTF 1/8-27		



Tie-rod kit classification (appendix "A")

Tie rod kit allows the correct assembly of sectional valves. Tie rod's length depends on the number of sections; each valve is assembled with tie rod kits including a tie rod, two nuts and two washers. D25 requires 4 tie-rod kits.

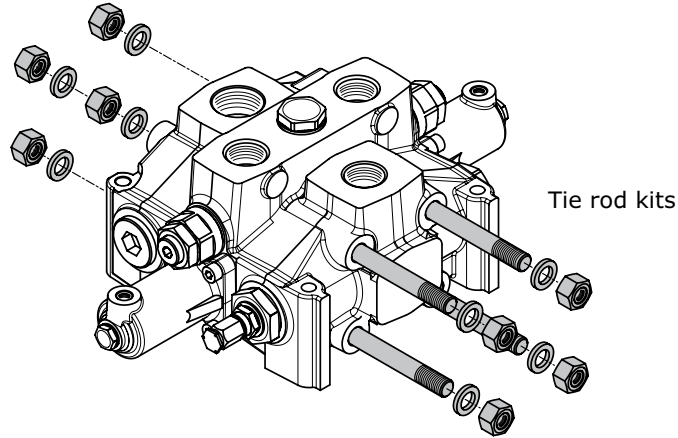

Tie rod kit	Order Code	Lenght (mm)	Clamping Torque (Nm)	Quantity
D25/1	300109001	276		
D25/2	300109002	350		
D25/3	300109003	424		
D25/4	300109004	498		
D25/5	300109005	572		
D25/6	300109006	646		
D25/7	300109007	720	110	4
D25/8	300109008	794		
D25/9	300109009	868		
D25/10	300109010	942		
D25/11	300109011	1016		
D25/12	300109012	1090		

Painting

On request, all Hydrocontrol valves can be delivered painted (RAL 9005 black primer).

Order example of D25/1 painted:

D25/1
 IR 009 150 A G07
 W001A H006 RP G07 01 PA 100 01 PB 100
 TJ A G08

P006/1 N10

The painting is indicated with the following value:

P006 - /1 - N10

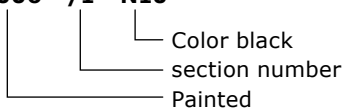



DIMENSIONS

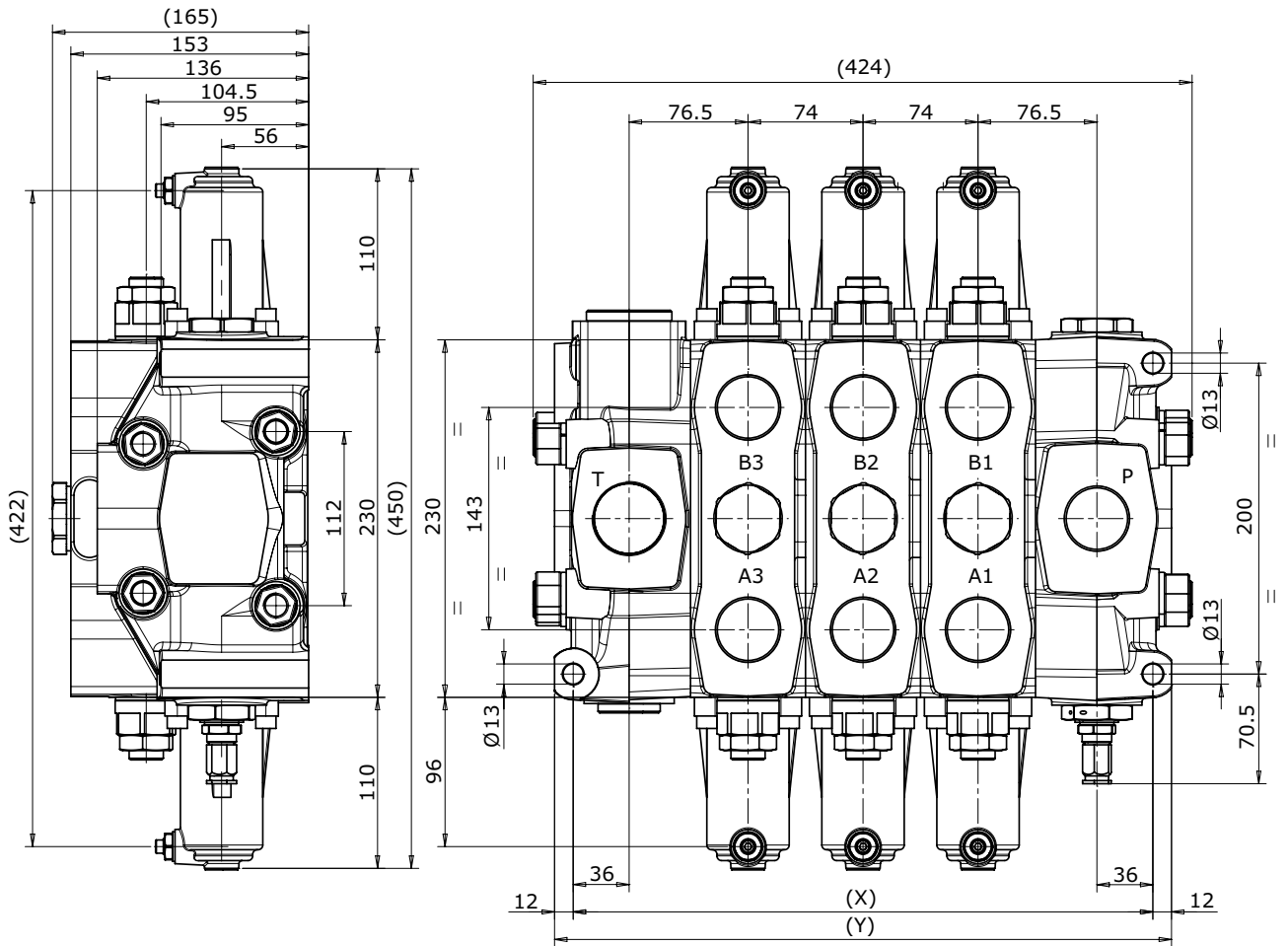

TYPE	/1	/2	/3	/4	/5	/6	/7	/8	/9	/10	/11	/12
X (mm)	225	299	373	447	521	595	669	743	817	891	965	1039
Y (mm)	249	323	397	471	545	619	693	767	841	915	989	1063
Weights (kg)	41,3	56,8	72,3	87,8	103,4	119	134,4	150	65,5	181	196,5	212



TYPICAL CURVES

Indicated values have been tested with standard sectional valve and W001A spool.

Pressure drop (P - T)

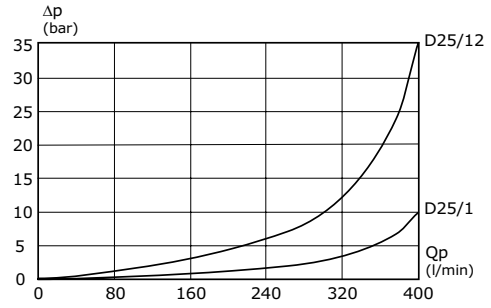
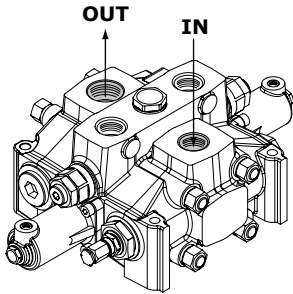

Pressure drop (P - A/B)

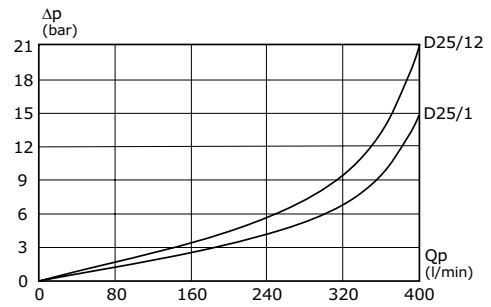
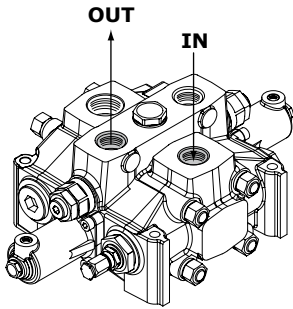

Pressure drop (A/B - T)

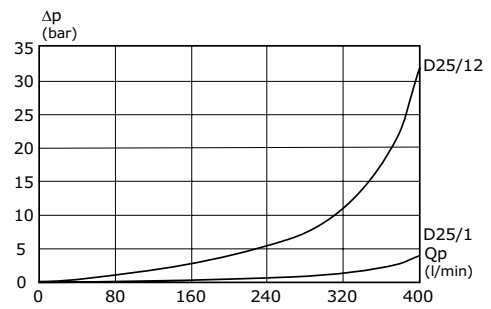
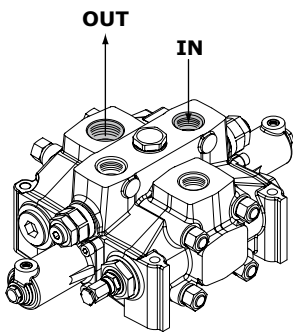

Pilot operated relief valve curve

Setting ranges	
type	pressure (bar)
A	0 - 350

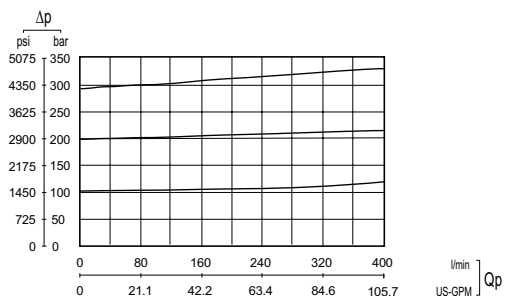



TYPICAL CURVES

Indicated values have been tested with standard sectional valve and W001A spool.

Antishock valve curve

Setting ranges		
type	pressure (bar)	
	at full flow	at min. flow
A	0 - 70	0-A / 50-A
A	71 - 120	51-A / 70-A
B	121 - 150	71-A / 110-A
C	151 - 300	111-A / 240-A
D	301 - 350	241-A / 350-A

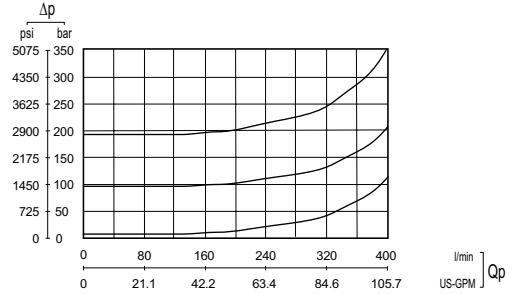

Combined valve curve

Setting ranges		
type	pressure (bar)	
	at full flow	at min. flow
A	50 - 130	20-A / 100-A
B	131 - 220	101-A / 220-A
C	221 - 260	221-A / 350-A

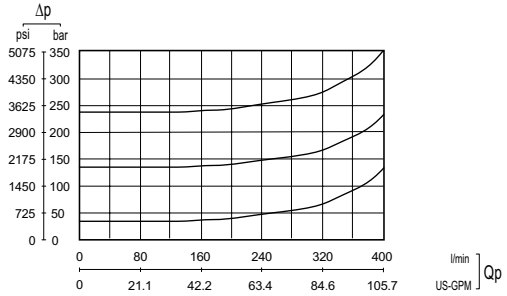

Main anticavitation check valve curve

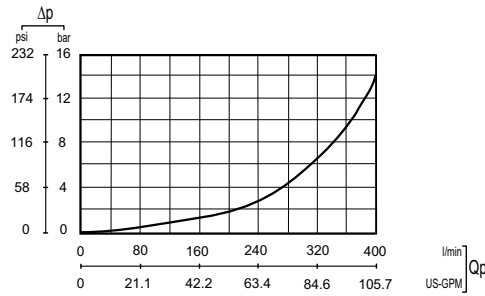

Anticavitation check valve curve

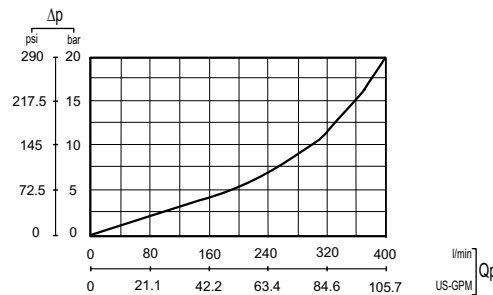



INLET SECTION

Order example

IR	009	150	A G07
----	-----	-----	-------

- 1. **IR** inlet side classification _____
- 009** valve arrangement _____
- 150** setting (bar) _____
- 2. **A G07** inlet position and available thread type _____

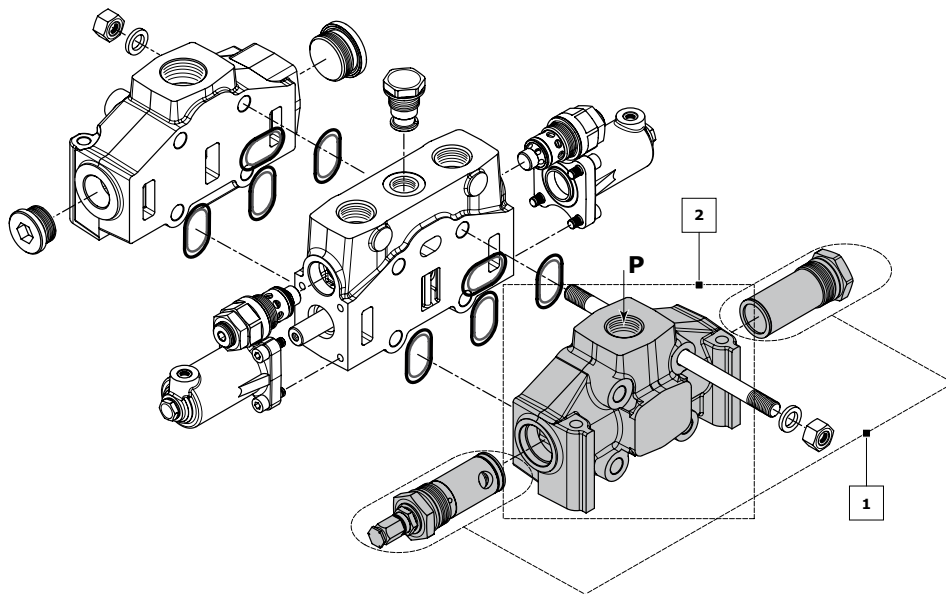

Rif.	Code	Description	Page
-	IR	Sectional valve with right inlet section	11
	IL	Sectional valve with left inlet section	
1	009	Pilot operated pressure relief valve	
	010	Pilot operated pressure relief valve and Main anticavitation check valve	12
	019	Without valves	
2	A G07	Upper inlet (thread G 1"1/4)	
	A U07	Upper inlet (thread 1"5/8 - 12 UNF)	13
	A S07	Upper inlet (thread SAE 3000 1"1/4 MA)	
	A S35	Upper inlet (thread SAE 6000 1" MA)	

NOTE: when ordering a relief valve it is necessary to specify factory setting (example 150).



Inlet side classifications

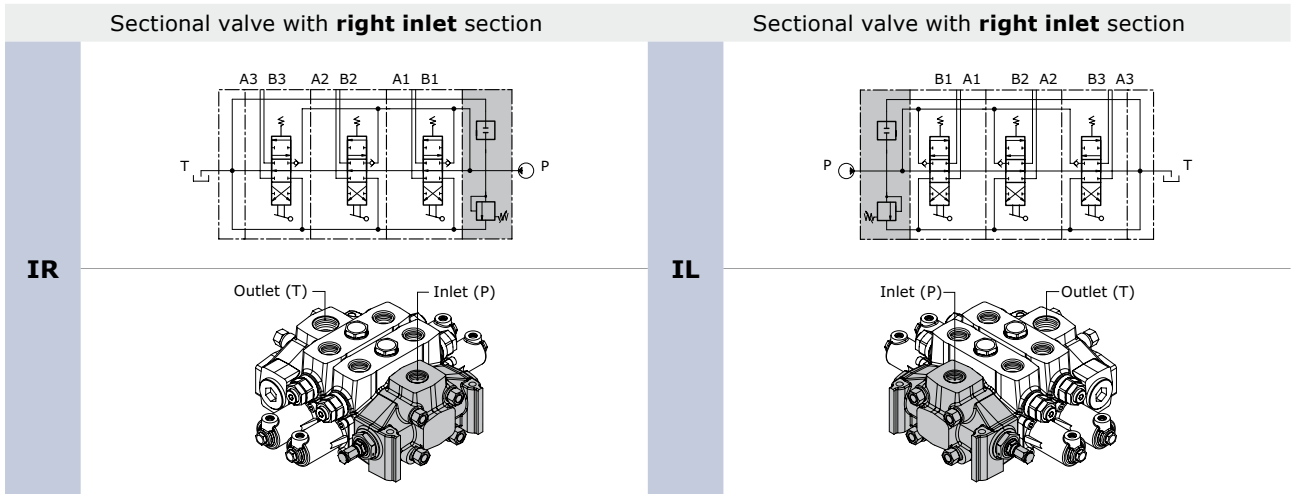

Valve identification

type	schema	layout	description	type	schema	layout	description
2			Pilot operated pressure relief valve	5			2 stage pilot operated relief valve
3			Relief valve plugged	6			Externally piloted valve
4			Main anticavitation check valve	11			Plug with pressure-gauge connection

Valve arrangement

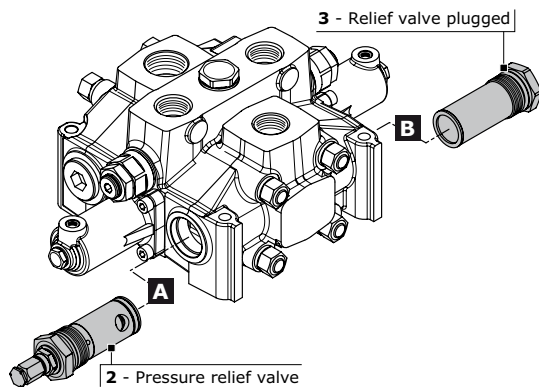













Combination valve example: 009 = 2A - 3B

- 009** Combination valve
- 2A** Pressure relief valve in port A
- 3B** Relief valve plugged in port B

The code identifies:
 with a number, the type of valve; with a letter its position on the inlet section.
 (A) = spool action side
 (B) = spool return action side
NOTE: when ordering a main relief valve it is necessary to specify setting



VALVE COMBINATION INLET SECTION		Valve type on port B						
								
		2	3	4	5	6	11	
Valve type on port A		2		009	010		011	016
		3	018	019	020	021	022	027
		4	029	030		031	032	037
		5		038				
		6	047	048				
		11	085					

NOTE: Valve combinations 021, and 038 requires double setting (see example).

Order example for inlet section: IR **038 200*280** A G05

038
200*380

valve combination _____
double range setting (bar) _____



Inlet combination and thread available	
A G07	Upper inlet (thread G 1"1/4)
A G08	Upper inlet (thread G 1"1/2)
A U07	Upper inlet (thread 1"5/8 - 12 UNF)
A S07	Upper inlet (thread SAE 3000 - 1"1/4 MA)
A S08	Upper inlet (thread SAE 3000 - 1"1/4 UNC)
A S35	Upper inlet (thread SAE 6000 - 1" MA)
A S36	Upper inlet (thread SAE 6000 - 1" UNC)
B G07	Upper inlet P1 with pressure-gauge connection G 1/4 (thread G 1"1/4)
B G08	Upper inlet P1 with pressure-gauge connection G 1/4 (thread G 1"1/2)
B U07	Upper inlet P1 with pressure-gauge connection G 1/4 (thread 1"5/8 - 12 UNF)
B S07	Upper inlet P1 with pressure-gauge connection G 1/4 (thread SAE 3000 - 1"1/4 MA)
B S08	Upper inlet P1 with pressure-gauge connection G 1/4 (thread SAE 3000 - 1"1/4 UNC)
B S35	Upper inlet P1 with pressure-gauge connection G 1/4 (thread SAE 6000 - 1" MA)
B S36	Upper inlet P1 with pressure-gauge connection G 1/4 (thread SAE 6000 - 1" UNC)
C G07	Central side inlet (thread G 1"1/4)
C G08	Central side inlet (thread G 1"1/2)
C U07	Central side inlet (thread 1"5/8 - 12 UNF)
C S07	Central side inlet (thread SAE 3000 - 1"1/4 MA)
C S08	Central side inlet (thread SAE 3000 - 1"1/4 UNC)
C S35	Central side inlet (thread SAE 6000 - 1" MA)
C S36	Central side inlet (thread SAE 6000 - 1" UNC)
D G07	Central side inlet P1 with pressure-gauge connection G 1/4 (thread G 1"1/4)
D G08	Central side inlet P1 with pressure-gauge connection G 1/4 (thread G 1"1/2)
D U07	Central side inlet P1 with pressure-gauge connection G 1/4 (thread 1"5/8 - 12 UNF)
D S07	Central side inlet P1 with pressure-gauge connection G 1/4 (thread SAE 3000 - 1"1/4 MA)
D S08	Central side inlet P1 with pressure-gauge connection G 1/4 (thread SAE 3000 - 1"1/4 UNC)
D S35	Central side inlet P1 with pressure-gauge connection G 1/4 (thread SAE 6000 - 1" MA)
D S36	Central side inlet P1 with pressure-gauge connection G 1/4 (thread SAE 6000 - 1" UNC)

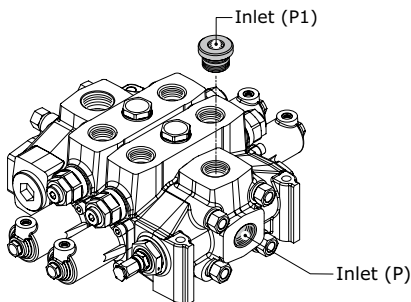
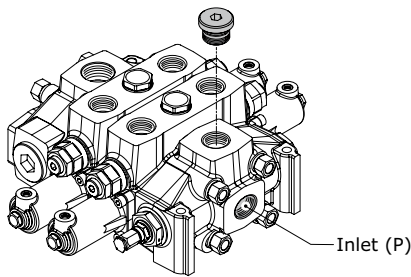
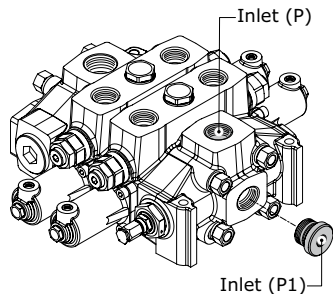
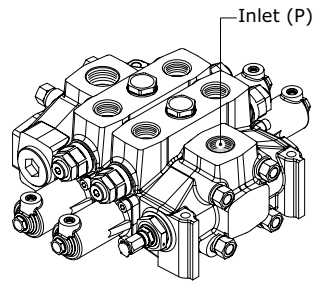



WORKING SECTION

Order example:

W001A	H006	RP G07	01 PA 100	01 PB 100
--------------	-------------	---------------	------------------	------------------

- | | |
|---|---|
| <ol style="list-style-type: none"> 1. W001A 2. H006 3. RP G07 4. 01 PA 100 5. 01 PB 100 | <p>spool type _____</p> <p>spool actuation type _____</p> <p>section and thread type _____</p> <p>auxiliary valve (port A - handle side) _____</p> <p>auxiliary valve (port B - cap side) _____</p> |
|---|---|

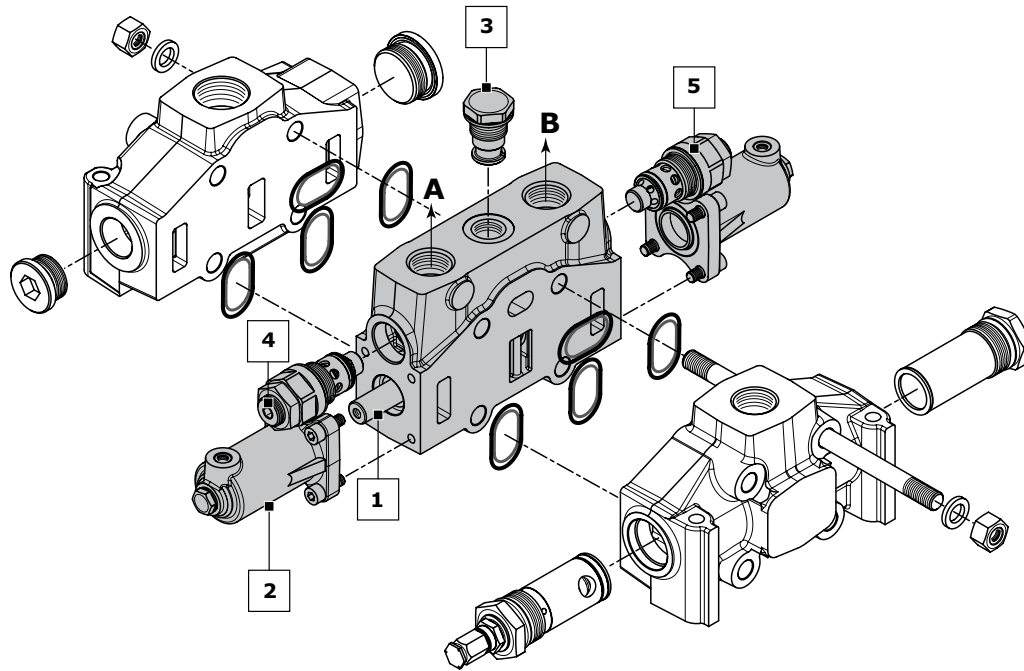

Rif.	Code	Description	Page
1	W001	3 positions double-acting	15
	W002	3 positions double-acting A-B to tank	
2	H101	Unprotected lever	17
	H006*	hydraulic actuation	
3	RP G07	Parallel circuit (G 1"1/4)	20
	RP U07	Parallel circuit (1"5/8-12 UNF)	
	RS G07	Series circuit (G 1"1/4)	
	RS U07	Series circuit (1"5/8-12 UNF)	
4	01 PA 100	Antishock valve (port A)	21
	05 PA	Prearrangement for auxiliary valve (port A)	
5	01 PB 100	Antishock valve (port B)	21
	05 PB	Prearrangement for auxiliary valve (port B)	

NOTE: (*) Leave out the spool return action code when choosing H006.
 Sections designed to house auxiliary valve option require double choice on work ports A and B.
 Always indicate setting value when using Antishock and Pilot combined valve: **01 PA (100) - 04 PA (100)**



Spool identification

order example of spool: **W001 A J10**

- W001** spool schema 3 positions double-acting
- A** spool type standard spool
- J10** restricted service ports restriction on diameter (0,10 mm in A and B)

W001	3 positions double-acting	
W002	3 positions double-acting A and B to tank	
W003	3 positions double-acting A to tank B blocked	
W004	3 positions double-acting A blocked B to tank	
W005	3 positions single - acting on A	
W006	3 positions single - acting on B	
W009	3 positions double-acting with anticavitation valves	
W010	3 positions double-acting switch port closed (A - B blocked)	
W011	3 positions double-acting switch port closed (A - B to tank)	
W012	4 positions double-acting with float in the 4th position	
W013	3 positions double-acting regenerative	
W015	3 positions double-acting series	
W016	3 positions double-acting series A and B to tank	



spools with restricted service ports				
code	circuit	restriction on diameter (mm)	section (mm ²)	hydraulic schema
J10	A-B IN T	0,10	4,71	
K10	A IN T	0,10	4,71	
Y10	B IN T	0,10	4,71	

CODE	spool type available	
	STANDARD A	METERED B
W001	W001A	W001B
W002	W002A	W002B
W003	W003A	W003B
W004	W004A	W004B
W005	W005A	W005B
W006	W006A	W006B
W009	W009A	W009B
W010	W010A	
W011	W011A	
W012	W012A	
W013	W013A	
W015	W015A	
W016	W016A	

NOTE:

- W012, W013, spools need a special machining on the valve body.
- W015, W016, spools need RS type body.
- Float spool (W012) need special detent kit (F005).
- Regenerative spool (W013) need special return spring kits.
- Different spools are available on request.

Please contact our Sales department for more information.



Spool actuation classification for manual control

code	description	dimensions	configuration
H101	Unprotected lever		
H102	Unprotected lever rotated 180°		

Spool actuation classification for Hydraulic control

code	description	dimensions	configuration
H006 <small>leave out the spool return action code</small>	Hydraulic actuation with side ports and cast-iron end caps BSP ports = G 1/4 UNF ports = 9/16-18 UNF		

Hydraulic pilot control curve

The diagram shows the spool stroke as a function of the pressure operating.

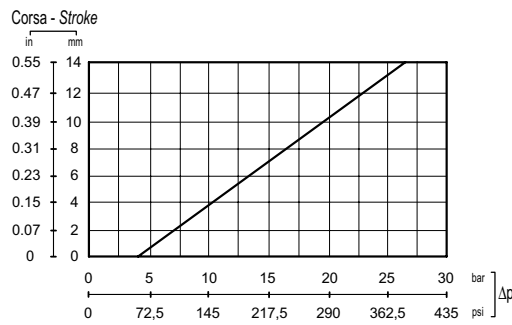



Spool return action classification - Springs load values

Spool return kits have three different spring types; following the codes depending on spring loads.

Spring type			
Code	A (standard spring)	B (soft spring)	C (heavy spring)
Preloading	155 N	116.7 N	188.3 N
End of stroke	373.7 N	152 N	454.3 N
Spool return action identification example			
Code	F001A	F001B	F001C

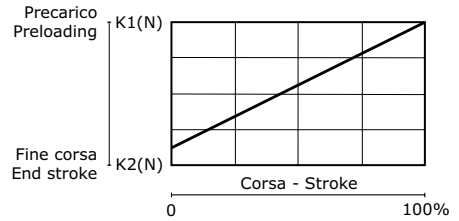

Spool return action classification

code	description	schema	dimensions	configuration
F001A F001B F001C	3 positions spring-centred spool			
F002A	3 positions spring-centred spool detent in A and B			
F003A	3 positions spring-centred spool detent in A			
F004A	3 positions spring-centred spool detent in B			
F005A	4 positions spring-centred spool detent in 4 th position (only for W012 spool)			



Compatibility table

SPOOL ACTION TYPE	SPOOL TYPE																				
	W001A	W001B	W002A	W002B	W003A	W003B	W004A	W004B	W005A	W005B	W006A	W006B	W009A	W009B	W010A	W011A	W012A	W013A	W015A	W016A	
H101	•	•	•	•	•	•	•	•	•	•	•	•	•	•	•	•	•	•	•	•	•
H102	•	•	•	•	•	•	•	•	•	•	•	•	•	•	•	•	•	•	•	•	•
H005	•	•	•	•	•	•	•	•	•	•	•	•	•	•	•	•	•	•	•	•	•
SPOOL RETURN ACTION TYPE	SPOOL TYPE																				
	W001A	W001B	W002A	W002B	W003A	W003B	W004A	W004B	W005A	W005B	W006A	W006B	W009A	W009B	W010A	W011A	W012A	W013A	W015A	W016A	
F001	•	•	•	•	•	•	•	•	•	•	•	•	•	•	•	•		•	•	•	•
F002	•	•	•	•	•	•	•	•	•	•	•	•	•	•	•	•			•	•	•
F003	•	•	•	•	•	•	•	•	•	•	•	•	•	•	•	•			•	•	•
F004	•	•	•	•	•	•	•	•	•	•	•	•	•	•	•	•			•	•	•
F005																	•				



Work section identification

working section type

- RP G07
- RP G08
- RP U07
- RP S07
- RP S08
- RP S35
- RP S36

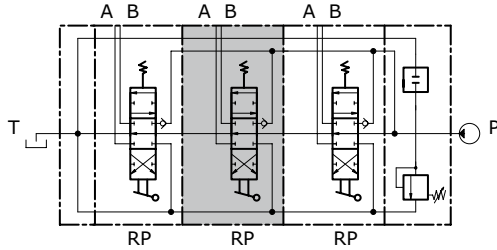

Parallel circuit section

When the spool is operated it intercepts the by-pass gallery by diverting the flow of oil to service port A or B. If two or more spools are actuated at the same time, the oil will power the service port that has the lower load; by throttling the spools, the flow of oil can be divided between two or more service ports.

- RS G07
- RS G08
- RS U07
- RS S07
- RS S08
- RS S35
- RS S36

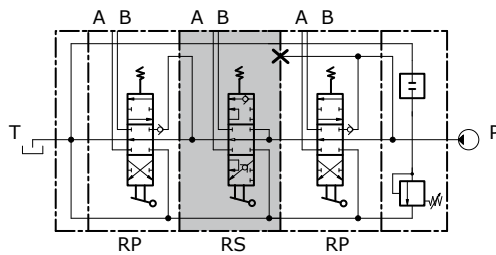

Series circuit section

When the spool is operated it intercepts the switch gallery by diverting the flow of oil to service port A or B. The oil that flows back from the actuator is carried to the switch gallery thus making it available to the service ports downstream from the series section. The pressure drop downstream is added to the pressure drop of the section itself.



Auxiliary valve identification

code	description	schema	configuration	setting range (bar)			
				type	at full flow	type	at min. flow
01 PA	Antishock valve (port A)			A	0 / 70	A	0-A / 50-A
				B	71 / 120	B	51-A / 70-A
				C	121 / 150	C	71-A / 110-A
				D	151 / 300	D	111-A / 240-A
				E	301 / 350	E	241-A / 350-A
02 PA	Anticavitation valve (port A)						
04 PA	Pilot combined valve (port A)			A	30 / 110		
				B	111 / 350		
05 PA	Prearrangement for auxiliary valve (port A)						

code	description	schema	configuration	setting range (bar)			
				type	at full flow	type	at min. flow
01 PB	Antishock valve (port B)			A	0 / 70	A	0-A / 50-A
				B	71 / 120	B	51-A / 70-A
				C	121 / 150	C	71-A / 110-A
				D	151 / 300	D	111-A / 240-A
				E	301 / 350	E	241-A / 350-A
02 PB	Anticavitation valve (port B)						
04 PB	Pilot combined valve (port B)			A	30 / 110		
				B	111 / 350		
05 PB	Prearrangement for auxiliary valve (port B)						

Auxiliary valve - Setting range

Sections designed to house auxiliary valve option require double choice on work ports A and B. Always indicate setting value when using antishock valve and pilot combined valve:

- 01 PA (120) = setting at full flow**
- 01 PA (120-A) = setting at min. flow**
- 04 PA (120) = setting at min. flow**



INTERMEDIATE INLET SECTION

Order example

BE	009	150	A G07
-----------	------------	------------	--------------

- 1. **BE** inlet side
- 009** valve arrangement
- 150** setting (bar); when ordering a main relief valve it is necessary to specify setting
- 2. **A G07** inlet position and available thread type

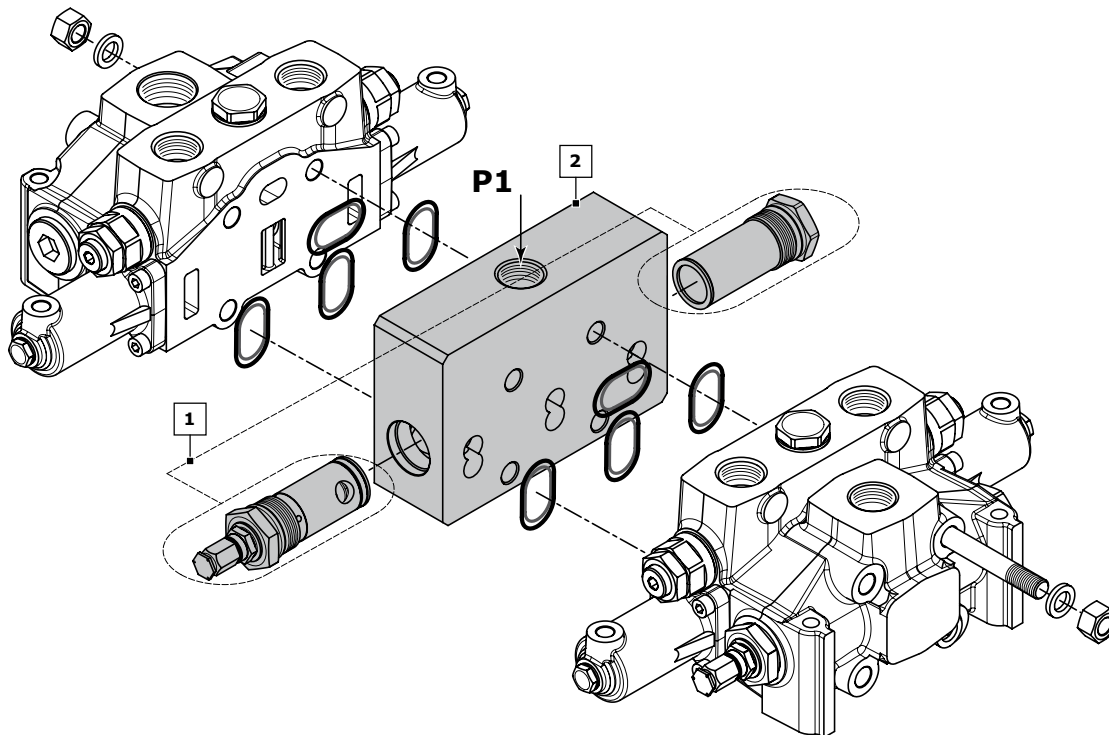

Rif.	Code	Description	Page
-	BE	Intermediate inlet section	23
	BV*	Intermediate inlet section with pressure relief valve	
1	009	Pilot operated pressure relief valve	24
	010	Pilot operated pressure relief valve and Main anticavitation check valve	
	019	Without valves	
	020	Main anticavitation check valve	
2	A G07	Upper inlet (thread G 1"1/4)	
	A U07	Upper inlet (thread 1"5/8-12 UNF)	

NOTE: when ordering a relief valve it is necessary to specify factory setting (example 150).
 * = omit the code for inlet positioning and thread



Intermediate inlet section classifications

intermediate inlet type

BE			Intermediate inlet section
-----------	--	--	----------------------------

The intermediate inlet section is driven by two pumps (P + P1). The downstream elements can be set to a lower pressure than the upstream ones by adjusting the pressure relief valve of the intermediate section in question.

BV			Intermediate inlet section with pressure relief valve
-----------	--	--	---

The intermediate inlet section and the elements are driven by a single pump (P). The downstream elements can be set to a lower pressure than the upstream ones by adjusting the pressure relief valve of the intermediate section in question.

Valve identification on intermediate inlet section

type	schema	layout	description	type	schema	configurazione	descrizione
2			Pilot operated pressure relief valve	4			Externally piloted valve
3			Relief valve plugged	11			Plug with pressure-gauge connection

Valve arrangement on intermediate inlet section

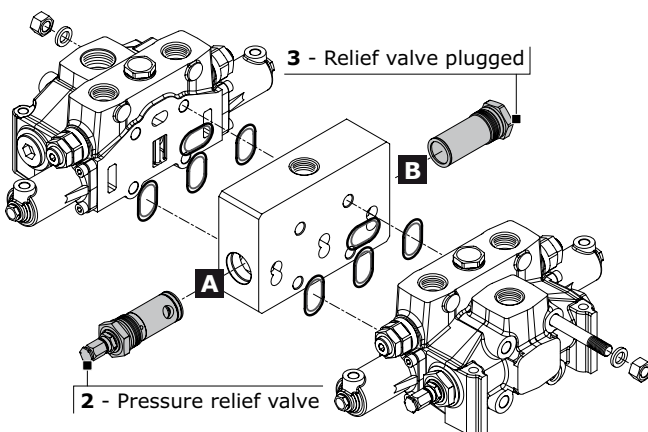

Combination valve example: 009 = 2A - 3B









- 009** Combination valve
- 2A** Pressure relief valve in port A
- 3B** Relief valve plugged in port B

The code identifies:
with a number, the type of valve; with a letter its position on the inlet section.

- (A) = spool action side
- (B) = spool return action side

NOTE: when ordering a main relief valve it is necessary to specify setting



		Valve type on port B			
					
VALVE COMBINATION INLET SECTION		2	3	4	11
Valve type on port A		2	009	010	016
		3	018	019	027
		4	029	030	
		11	085	086	

Inlet combination and thread available

- A G07
- A G08
- A U07
- A S07
- A S08
- A S35
- A S36

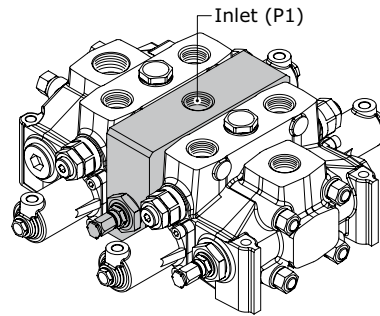

Upper inlet

Complete configuration samples for D25/2 with intermediate inlet section (BE)

- IR 009 150 A G07..... Right inlet section
- W001A H006 RP G07 Working section
- BE 009 150 A G07Intermediate inlet section**
- W001A H006 RP G07 Working section
- TJ A G08 Outlet section

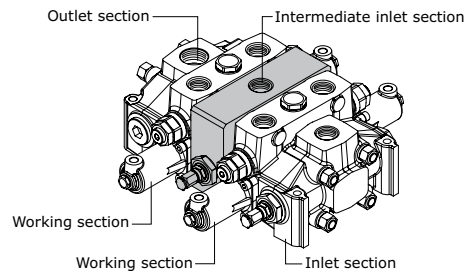

Complete configuration samples for D25/2 with intermediate inlet section (BV)

- IR 009 150 A G07..... Right inlet section
- W001A H006 RP G07 Working section
- BV 009 150Intermediate inlet section**
- W001A H006 RP G07 Working section
- TJ A G08 Outlet section

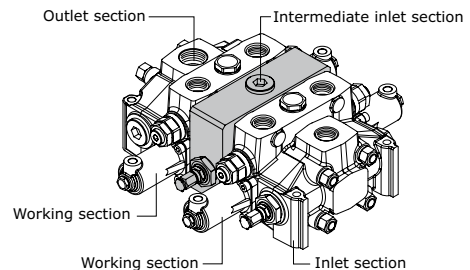



INTERMEDIATE OUTLET SECTION

Order example

BF | **A G08**

1. **BF** inlet side _____
A G08 inlet position and available thread type _____

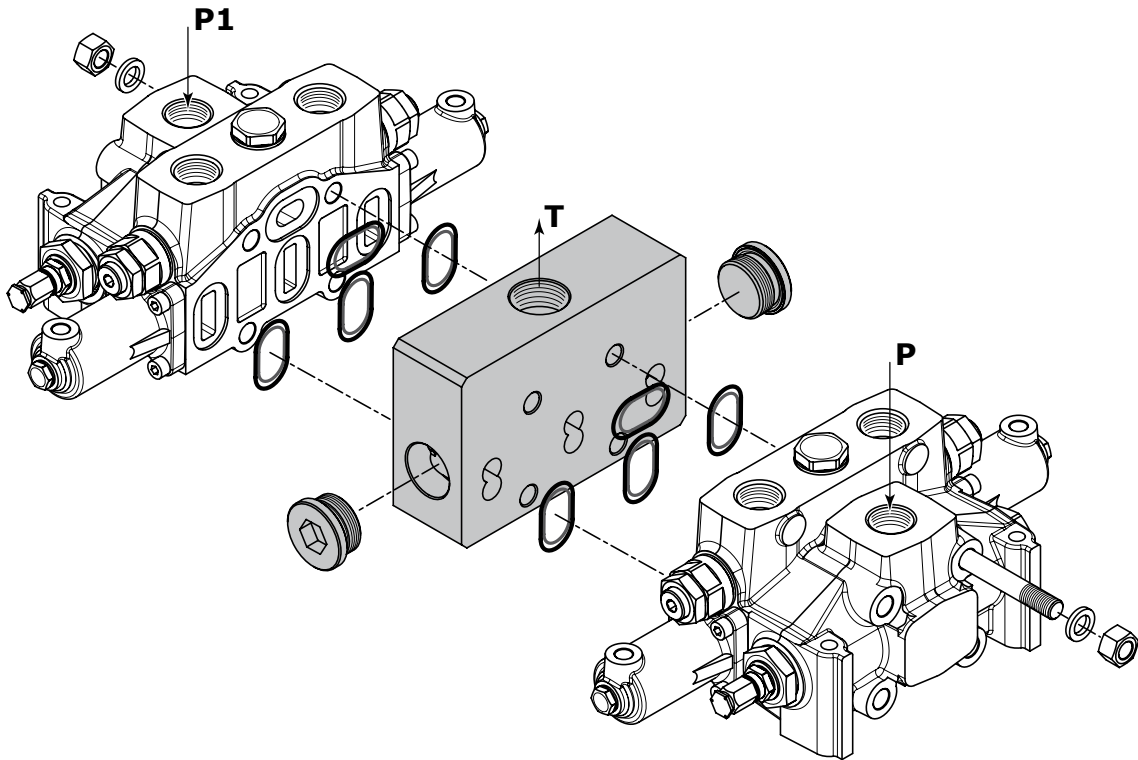

Rif.	Code	Type	Description	Page
-	BF		Intermediate outlet section with single tank return	
	BG		Intermediate outlet section with two tank returns	
1	A G08		Upper outlet (thread G 1"1/2)	26
	A U07		Upper outlet (thread 1"5/8-12 UNF)	
	G G08	for	Front outlet side A (thread G 1"1/2)	
	G U07	BF	Front outlet side A (thread 1"5/8-12 UNF)	
	H G08		Rear outlet side B (thread G 1"1/2)	
	H U07		Rear outlet side B (thread 1"5/8-12 UNF)	
	J G08	for	Upper outlet HPCO - front side A and rear side B to T (thread G 1"1/2)	
	J U07	BG	Upper outlet HPCO-front side A and rear side B to T (thread 1"5/8-12 UNF)	



Intermediate outlet section classifications

intermediate outlet type

BF

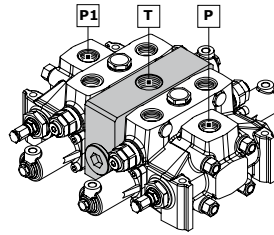
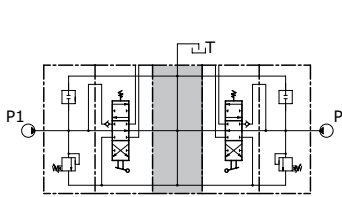

Intermediate outlet section with **single tank return**

The above outlet section allows the flow of oil of the two pumps and the tank ports to be piped to a single outlet T.

BG

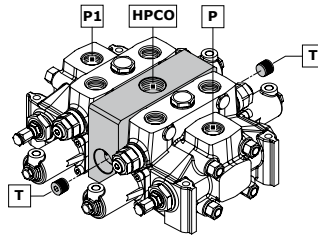
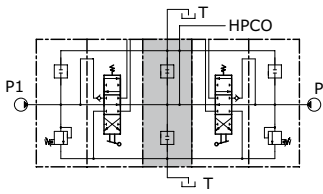

Intermediate outlet section with **two tank returns**

The section in question allows the flow of oil of the two pumps to be piped in two outlets: HPCO for powering another directional control valve, T for discharge of the work ports. In order to obtain this, the two T need to be linked.

Outlet position and available thread type (for BF intermediate)

Outlet combination and thread available

A G08
A U07
A S09
A S10
G G08
G U07
G S09
G S10
H G08
H U07
H S09
H S10

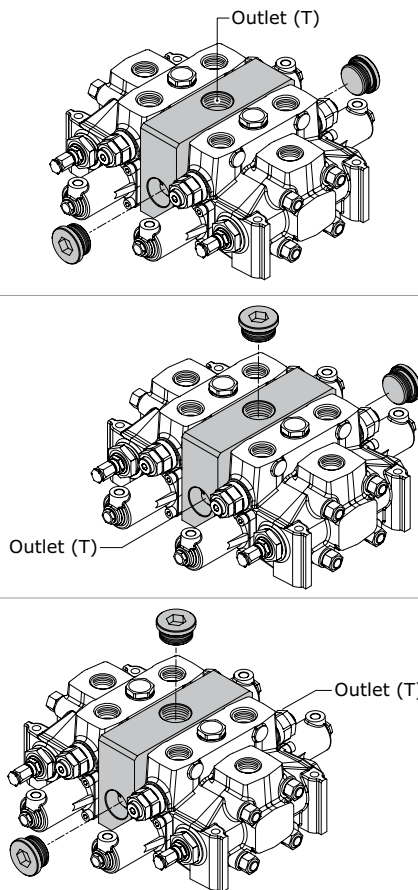

Upper outlet (T)

Front outlet side A (T)

Rear outlet side B (T)

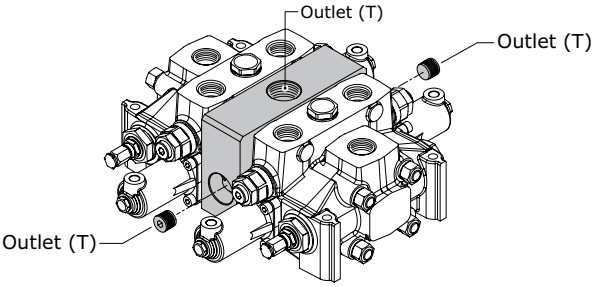

Outlet position and available thread type (for BG intermediate)

Inlet combination and thread available	
J G08	
J U07	
J S09	
J S10	

Upper outlet HPCO front side A and rear side B to T

Complete configuration samples for D25/2 with intermediate outlet section (BF)

- IR 009 150 A G07..... Right inlet section
- W001A H006 RP G07 Working section
- BF A G08Intermediate outlet section**
- W001A H006 RP G07 Working section
- IL 009 150 A G07..... Left inlet section

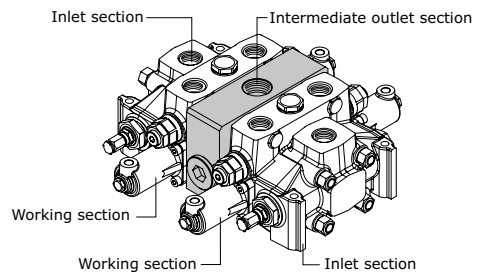

Complete configuration samples for D25/2 with intermediate outlet section (BG)

- IR 009 150 A G07..... Right inlet section
- W001A H006 RP G07 Working section
- BG J G08Intermediate outlet section**
- W001A H006 RP G07 Working section
- IL 009 150 A G07..... Left inlet section

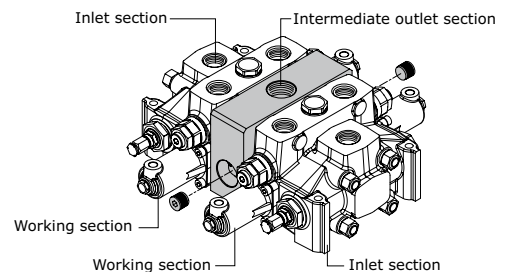



OUTLET SECTION (VERSION 1 OUTLET)

Order example

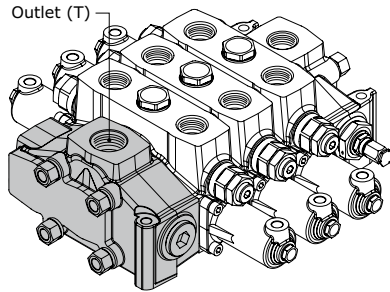

TJ | **A G08**

1. **TJ** outlet section type
2. **A G08** outlet position and available thread type

Rif.	Code	Description	Page
1	TJ	Outlet section with single return (T) right-side inlet (P)	
	TK	Outlet section with single return (T) left-side inlet (P)	
2	A G08	Upper outlet (thread G 1"1/2)	29
	A U07	Upper outlet (thread 1"5/8-12 UNF)	
	A S09	Upper outlet (thread SAE 3000 - 1"1/2 MA)	
	A S10	Upper outlet (thread SAE 3000 - 1"1/2 UNC)	
	C G08	Central outlet (thread G 1"1/2)	
	C U07	Central outlet (thread 1"5/8-12 UNF)	
	C S09	Central outlet (thread SAE 3000 - 1"1/2 MA)	
C S10	Central outlet (thread SAE 3000 - 1"1/2 UNC)		

OUTLET SECTION (HPCO VERSION OUTLET)

Order example - HPCO version Outlet

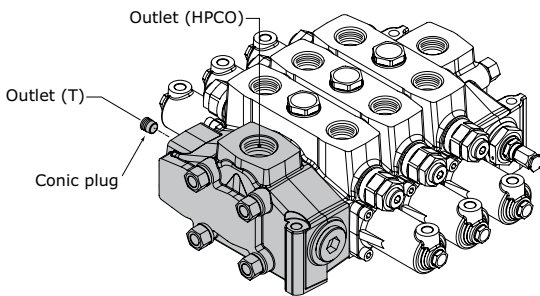

TM | **M G08**

1. **TM** outlet section type
2. **M G07** outlet position and available thread type

Rif.	Code	Description	Page
1	TM	Outlet section with two return (T-HPCO) right-side inlet (P)	
	TN	Outlet section with two return (T-HPCO) left-side inlet (P)	
2	M G08	HPCO upper outlet T (tank) rear outlet side B (thread G 1"1/2)	30
	M U07	HPCO upper outlet T (tank) rear outlet side B (thread 1"5/8-12 UNF)	
	M S09	HPCO upper outlet T (tank) rear outlet side B (thread SAE 3000 - 1"1/2 MA)	
	M S10	HPCO upper outlet T (tank) rear outlet side B (thread SAE 3000 - 1"1/2 UNC)	
	N G08	HPCO upper outlet T (tank) front outlet side A (thread G 1"1/2)	
	N U07	HPCO upper outlet T (tank) front outlet side A (thread 1"5/8-12 UNF)	
	N S09	HPCO upper outlet T (tank) front outlet side A (thread SAE 3000 - 1"1/2 MA)	
	N S10	HPCO upper outlet T (tank) front outlet side A (thread SAE 3000 - 1"1/2 UNC)	



Outlet with single tank classification

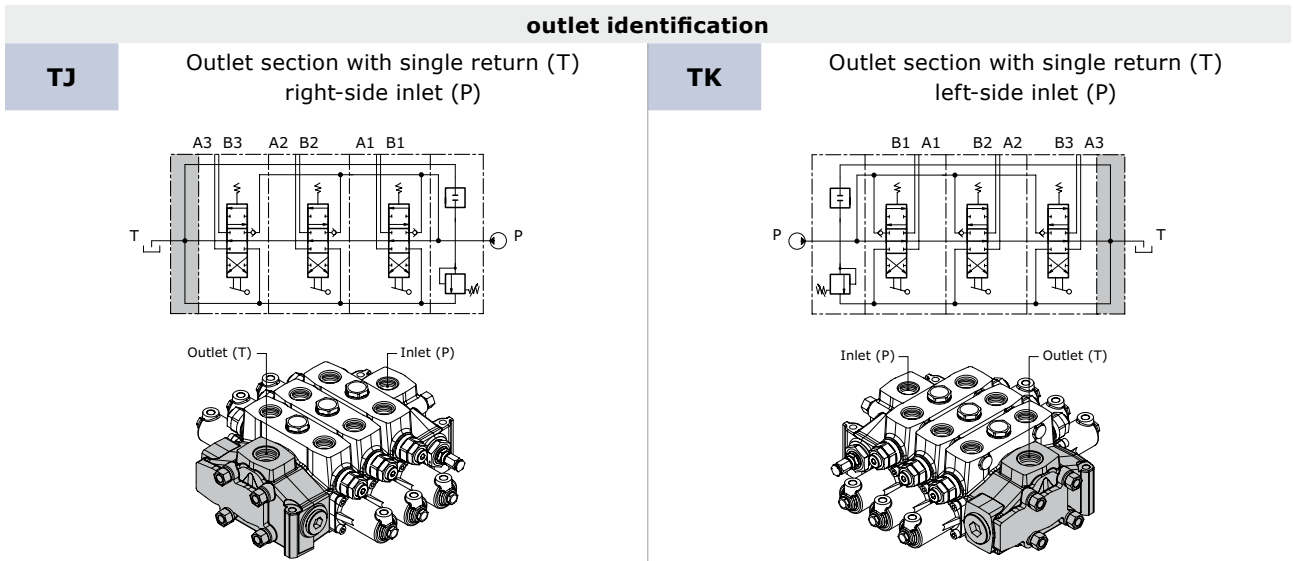

outlet combination and thread available

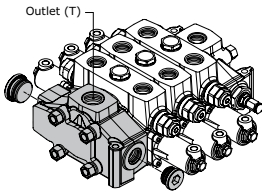
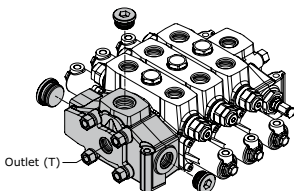
A G08		Upper outlet (thread G 1 1/2)	
A U07		Upper outlet (thread 1 5/8 - 12 UNF)	
A S09		Upper outlet (thread SAE 3000 - 1 1/2 MA)	
A S10		Upper outlet (thread SAE 3000 - 1 1/2 UNC)	
C G08		Central outlet (thread G 1 1/2)	
C U07		Central outlet (thread 1 5/8 - 12 UNF)	
C S09		Central outlet (thread SAE 3000 - 1 1/2 MA)	
C S10		Central outlet (thread SAE 3000 - 1 1/2 UNC)	
G G08		only for TK	Front outlet side A (thread G 1 1/2)
G U07			Front outlet side A (thread 1 5/8 - 12 UNF)
G S09	Front outlet side A (thread SAE 3000 - 1 1/2 MA)		
G S10	Front outlet side A (thread SAE 3000 - 1 1/2 UNC)		
H G08	only for TJ	Rear outlet side B (thread G 1 1/2)	
H U07		Rear outlet side B (thread 1 5/8 - 12 UNF)	
H S09		Rear outlet side B (thread SAE 3000 - 1 1/2 MA)	
H S10		Rear outlet side B (thread SAE 3000 - 1 1/2 UNC)	



Outlet with two tanks classification

outlet identification

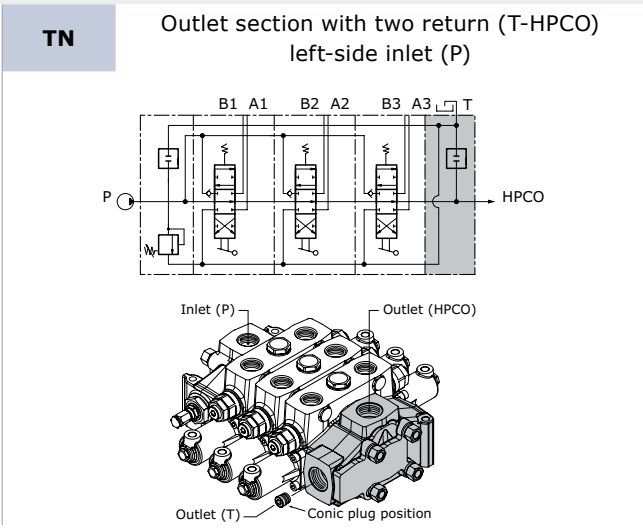
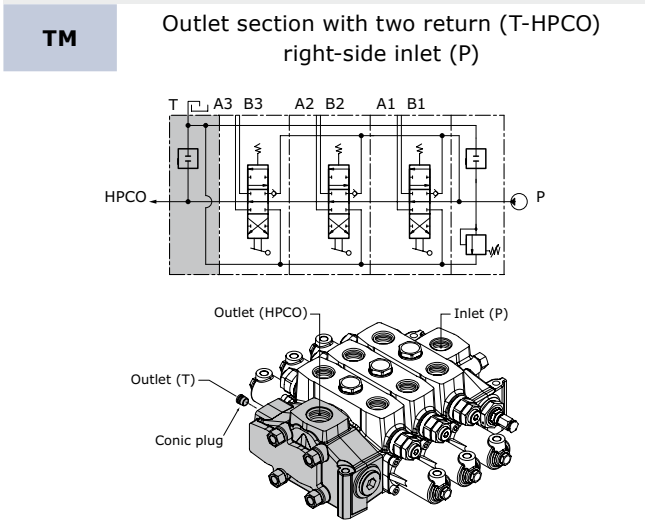

outlet combination and thread available

M G08 M U07 M S09 M S10 M S37 M S38		only for TM	HPCO Upper outlet T rear outlet side B (G 1 1/2)	P G08		only for TN	HPCO Central outlet T rear outlet side B (thread G 1 1/2)
			HPCO Upper outlet T rear outlet side B (1 5/8-12 UNF)	P U07			HPCO Central outlet T rear outlet side B (1 5/8-12 UNF)
			HPCO Upper outlet T rear outlet side B (SAE 3000 1 1/2 MA)	P S09			HPCO Central outlet T rear outlet side B (SAE 3000 1 1/2 MA)
			HPCO Upper outlet T rear outlet side B (SAE 3000 1 1/2 UNC)	P S10			HPCO Central outlet T rear outlet side B (SAE 3000 1 1/2 UNC)
			HPCO Upper outlet T rear outlet side B (SAE 6000 1 1/4 MA)	P S37			HPCO Central outlet T rear outlet side B (SAE 6000 1 1/4 MA)
			HPCO Upper outlet T rear outlet side B (SAE 6000 1 1/4 UNC)	P S38			HPCO Central outlet T rear outlet side B (SAE 6000 1 1/4 UNC)
N G08 N U07 N S09 N S10 N S37 N S38		only for TN	HPCO Upper outlet T front outlet side A (G 1 1/2)	Q G08		only for TM	HPCO Central outlet T front outlet side A (G 1 1/2)
			HPCO Upper outlet T front outlet side A (1 5/8-12 UNF)	Q U07			HPCO Central outlet T front outlet side A (1 5/8-12 UNF)
			HPCO Upper outlet T front outlet side A (SAE 3000 1 1/2 MA)	Q S09			HPCO Central outlet T front outlet side A (SAE 3000 1 1/2 MA)
			HPCO Upper outlet T front outlet side A (SAE 3000 1 1/2 UNC)	Q S10			HPCO Central outlet T front outlet side A (SAE 3000 1 1/2 UNC)
			HPCO Upper outlet T front outlet side A (SAE 6000 1 1/4 MA)	Q S37			HPCO Central outlet T front outlet side A (SAE 6000 1 1/4 MA)
			HPCO Upper outlet T front outlet side A (SAE 6000 1 1/4 UNC)	Q S38			HPCO Central outlet T front outlet side A (SAE 6000 1 1/4 UNC)



CARRY-OVER CONNECTION (HPCO)

This option, available on all D25, allows the sectional valve to feed a second valve, by extending the free flow channel. In this configuration, the valve need a separated port for connection to tank.

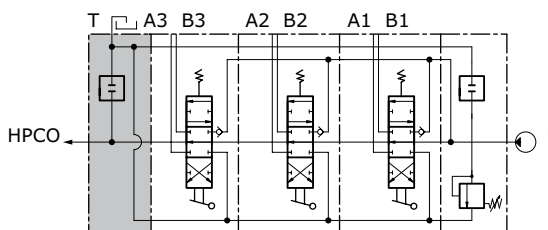

It is possible to transform sectional valve from standard to HPCO version just by ordering the appropriate conic plug:

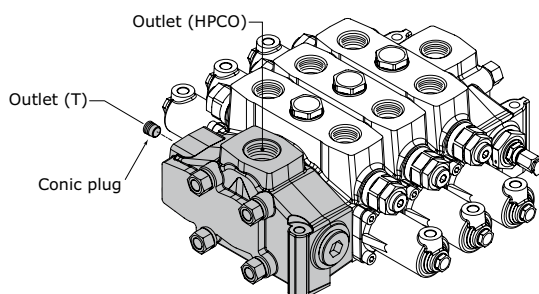

code (HPCO Plug identification)	description	q.ty
413010201	conic plug G 1/2 x 17	2



D25 SPARE PARTS LIST

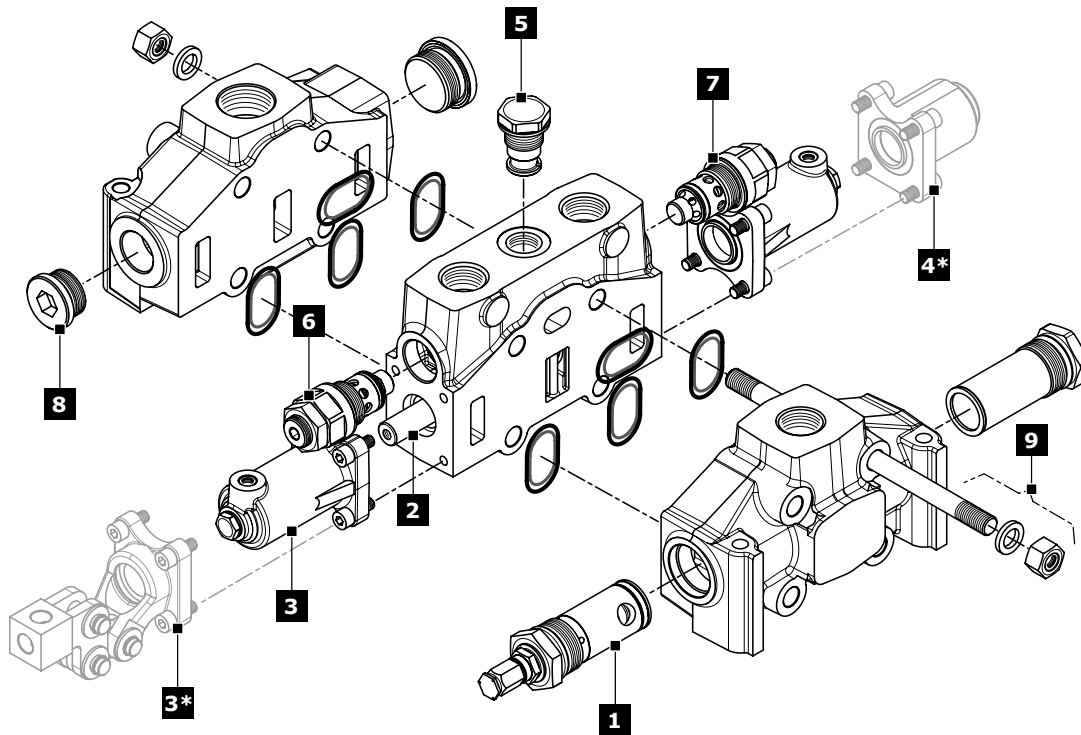

Ref.	Description	Order code	Q.ty	Code	Note
1	Pilot operated pressure relief valve (*)	30168			Setting: 100 bar
		3143	1		Setting: 200 bar
		4383			Setting: 300 bar
	Relief valve plugged	430109001	1	-	
	Main Anticavitation check valve	915050901	1		
2	3 positions double-acting spool	421209015		W001A	
		421209029	1	W001B	
		421209003		W001A	for hydraulic actuation
		421209007		W002A	
	3 positions double-acting A and B to tank spool	421209042	1	W002B	
		421209004		W002A	for hydraulic actuation
	3 positions single-acting on A	421209022	1	W005A	
	3 positions single-acting on B	421209023	1	W006A	
	4 positions double-acting with float in the 4 th pos.	421209018		W012A	
		421209017	1		for hydraulic actuation
3*	Protected lever	320309001		H101=H102	
		320309003			only for W012 spool
3	Hydraulic actuation with side ports	320509001	2		for BSP version
		320509006	1	H005	only for W012 spool - for BSP version
		320509012	2		for UNF version
		320509017	1		only for W012 spool - for UNF version



Ref.	Description	Order code	Q.ty	Code	Note
4*	3 position spring centred spool	320709004	1	F001A	
	Detent in A and B	320809001	1	F002A	
	Detent in A	320809002	1	F003A	
	Detent in B	320809003	1	F004A	
	Detent in 4 th position	320809004	1	F005A	only for W012 spool
5	Check valve on the work section	320209001	1	-	only for RP and RT section
6	Antishock valve on port A	3027	1		Setting: 100 bar
		2647		01 PA	Setting: 200 bar
		2781			Setting: 300 bar
	Anticavitation valve on port A	915080801		02 PA	
		15888			Setting: 100 bar
	Pilot combined valve on port A	5091		04 PA	Setting: 200 bar
		8943			Setting: 300 bar
	Prearrangement for auxiliary valve on port A	430409001		05 PP	
	7	Antishock valve on port B	3027	1	
		2647	01 PB		Setting: 200 bar
		2781			Setting: 300 bar
Anticavitation valve on port B		915080801		02 PB	
		15888			Setting: 100 bar
Pilot combined valve on port B		5091		04 PB	Setting: 200 bar
		8943			Setting: 300 bar
Prearrangement for auxiliary valve on port B		430409001		05 PB	
8		Plug kit (G 1"1/4)	430000022		G07
	Plug kit (1"5/8-12 UNF)	300009002		U07	

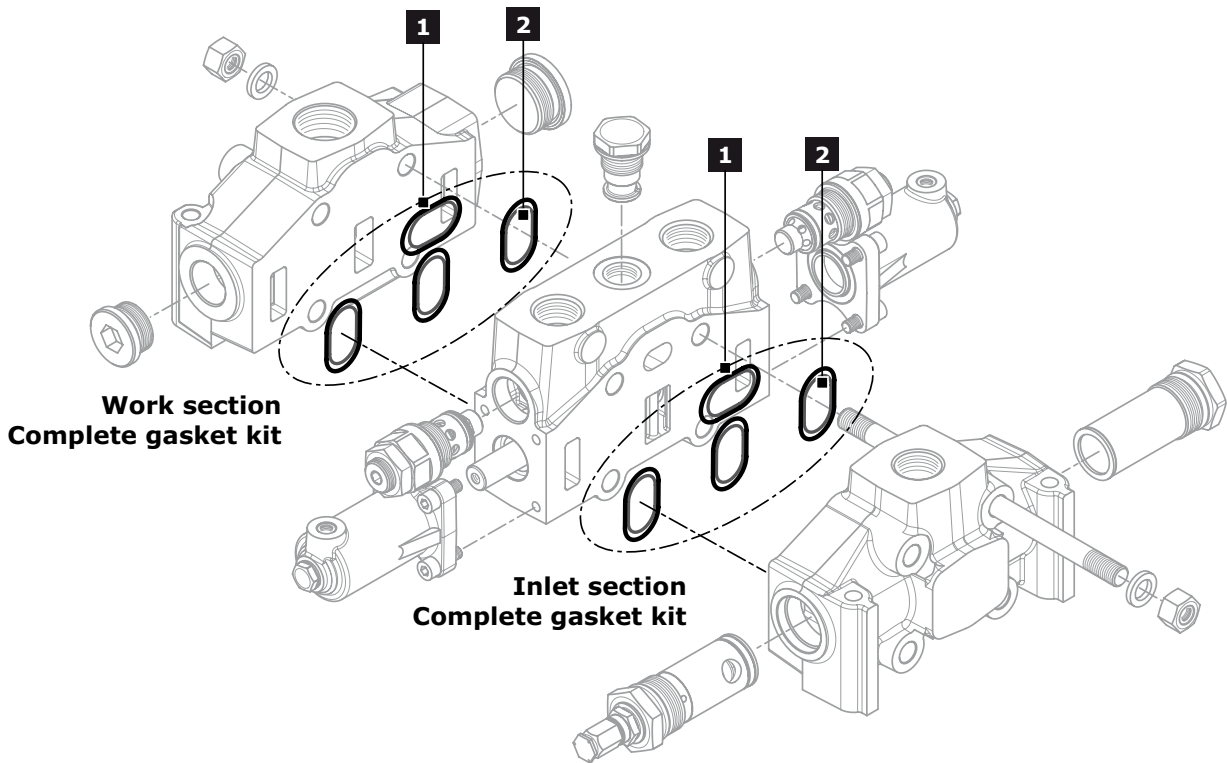

Inlet and work section			
Rif.	Order code	Description	Q.ty
1	423401017	Ring	4
2	412020603	O.R. 90SH (2-129)	4

Complete Gasket kit: order code - 350909001



INSTALLATION

Guidelines

- Mount the control valve securely to a flat surface (recommended 3 point fixing); at the time do not use a hammer to positioning by hitting.
- When handling the control valve, be careful not hold the pilot cover or return spring cap of the spool or accessory valves such as main relief valves and anti-shock relief valves.
- Clean piping materials sufficiently before use.
- Make sure to prevent the port openings from being entered with dust or foreign matters.
- Tighten the port connectors surely with the recommended fastening torques.
- Do not direct the jet of a pressure washing unit directly to the valve.

Fittings tightening torque (Nm)

thread type	port P	Port A - B	Port T
BSP (ISO - 228)	G 1"1/2	G 1"1/2	G 1"1/2
with rubber sealing (DIN 3869)	120	120	120
with copper or steel and rubber washer	120	120	120
BSP (ISO - 228)	G 1"1/4	G 1"1/4	G 1"1/4
with rubber sealing (DIN 3869)	120	120	120
with copper or steel and rubber washer	120	120	120
UN-UNF (ISO - 725)	1"1/16 12 UNF	1"1/16 12 UNF	1"1/16 12 UNF
with O.R.	120	120	120
UN-UNF (ISO - 725)	1"5/16 12 UNF	1"5/16 12 UNF	1"5/16 12 UNF
with O.R.	120	120	120

General clamping torque

The following table provides the main tightening torques of the distributor D25:

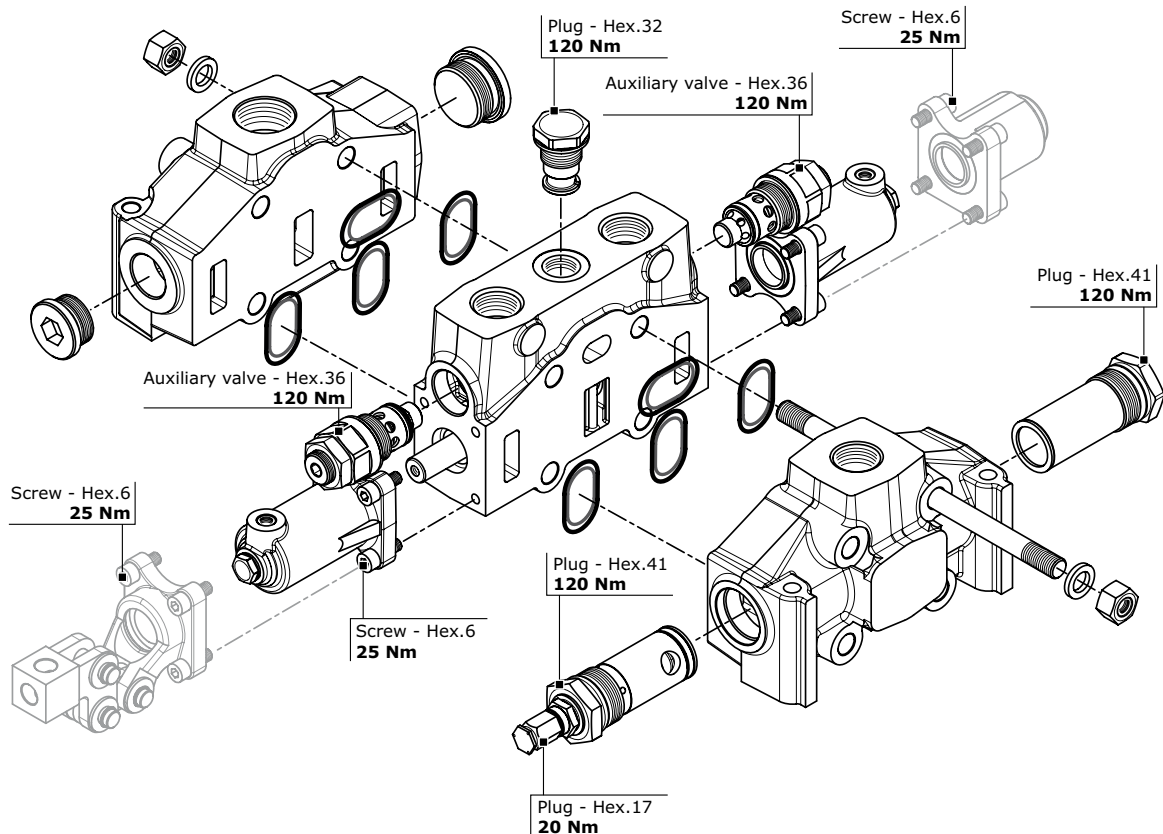



Dimensions - Thread codes

The connection ports size is indicated by an ordering code common for all Hydrocontrol products. Following table shows all available connections.

METRIC THREAD (ISO 9974-1)

Type	M18x1,5	M22x1,5	M27x2
Code	M01	M02	M03

BSP THREAD (ISO 1179-1)

Type	1/4"	3/8"	1/2"	3/4"	1"	1"1/4	1"1/2	2"
Code	G02	G03	G04	G05	G06	G07	G08	G09

UN / UNF THREAD (ISO 11926-1)

Type	9/16" 18 UNF SAE6	3/4" 16 UNF SAE8	7/8" 14 UNF SAE10	1"1/16 12 UNF SAE12	1"5/16 12 UNF SAE16	1"5/8 12 UNF SAE20
Code	U02	U03	U04	U05	U06	U07

Dimensions - SAE Flange codes

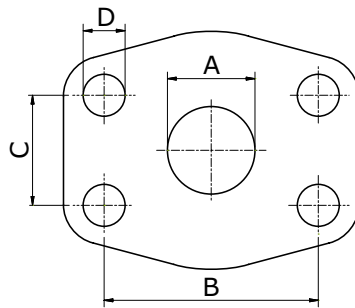
**SAE / 3000 FLANGE (ISO 6162-1)**

Type	3/4" (MA)	3/4" (UNC)	1" (MA)	1" (UNC)	1"1/4 (MA)	1"1/4 (UNC)	1"1/2 (MA)	1"1/2 (UNC)	2" (MA)	2" (UNC)	3" (MA)	3" (UNC)
Code	S03	S04	S05	S06	S07	S08	S09	S10	S11	S12	S15	S16
A	19	19	25	25	32	32	38	38	51	51	76	76
B	47,6	47,6	52,4	52,4	58,7	58,7	69,9	69,9	77,8	77,8	106,4	106,4
C	22,3	22,3	26,2	26,2	30,2	30,2	35,7	35,7	42,9	42,9	61,9	61,9
D	M10	3/8-16	M10	3/8-16	M10	7/16-14	M12	1/2-13	M12	1/2-13	M16	5/8-11

SAE / 6000 FLANGE (ISO 6162-2)

Type	3/4" (MA)	3/4" (UNC)	1" (MA)	1" (UNC)	1"1/4 (MA)	1"1/4 (UNC)	1"1/2 (MA)	1"1/2 (UNC)
Code	S33	S34	S35	S36	S37	S38	S39	S40
A	19	19	25	25	32	32	38	38
B	50,8	50,8	57,2	57,2	66,6	66,6	79,3	79,3
C	23,8	23,8	27,8	27,8	31,8	31,8	36,5	36,5
D	M10	3/8-16	M12	7/16-14	M14	1/2-13	M16	5/8-11



GENERAL CONDITIONS AND PATENTS

Product identification

All Hydrocontrol products have an identifying plate placed in specific position.

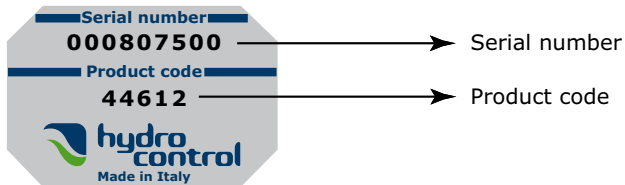

Serial number:

It univocally identifies the physical valve: this provides an easy way to find all sales and production details.

Product code:

It is a number univocally identifying the configuration and pressure settings of a valve.

Introduction

These general conditions apply to all general supplies from Hydrocontrol s.p.a., after receiving orders from the Customer. Should commercial terms such as EXW, DDP, etc be mentioned, of course the Incoterms of the International Chamber of Commerce must be referred to, according to the test existing when the general supply conditions are agreed on.

Management of orders

No Customer's order is binding to Hydrocontrol s.p.a. if Hydrocontrol s.p.a. has not confirmed the order in writing. Hydrocontrol s.p.a. commits to supplying the orders in compliance with the order confirmation that has been issued. Any disagreement with the content of the order confirmation must be communicated in writing to Hydrocontrol s.p.a. within and no later than 5 days from the delivery of the order confirmation. The Customer commits to paying for the goods supplied by Hydrocontrol s.p.a., according to the prices indicated on the order confirmation.

Payment conditions

The Parties agree on the payment terms at the beginning of the supply. The terms will be indicated on the order confirmation. Should the Customer be late with the payments, Hydrocontrol S.p.a. will be entitled to require the payment of interests on arrears based on the exiting Prime Rate increased by 2%. Should there be any payment delay, Hydrocontrol s.p.a. will be entitled not to process the Customer's purchase order, even if it has already been confirmed.

Delivery and shipment

The goods are always supplied Ex Works, even when Hydrocontrol s.p.a. agrees with the Customer that the shipment, or a part of it, will be arranged by Hydrocontrol s.p.a. It is agreed that the Customer will bear the risk of goods deterioration or damaging from the moment the goods are handed by Hydrocontrol s.p.a. to the first carrier.

Product characteristics

Hydrocontrol s.p.a. commits to supplying good quality products, compliant with the technical specifications declared on the technical tables and on the catalogue. Hydrocontrol s.p.a, even without notice, at its own discretion, reserves the right to modify the products as necessary, without these changes altering the main characteristics of the products.

Claims

Any claims about defects on delivered products (just as an example: claims about the packaging, the number, the quantity or the external product characteristics) will have to be notified to Hydrocontrol s.p.a. in writing, within and no later than 7 days from reception of the goods, otherwise the claims will be considered as null and void. Occult defects (the defects of the goods that cannot be spotted with a careful control of the goods received by the Customer), will have to be notified in writing to Hydrocontrol s.p.a. within 7 days from the discovery of the defect, and anyhow no later than 12 months from the delivery of the goods, otherwise the claim will be considered as null and void. Even in case of claim or objection, the Customer will never be entitled to suspend or delay the payments to Hydrocontrol s.p.a. for the products subject to claim or objection nor for any other supply.

**GENERAL CONDITIONS AND PATENTS****Warranty**

Should the products supplied by Hydrocontrol not be compliant or have the required quality and should this defect be due to Hydrocontrol, Hydrocontrol s.p.a. commits, at its choice, to replace or repair the faulty products, as long as the defect or lack of compliance is notified to Hydrocontrol s.p.a. in writing, as specified at point 6, within and no later than 18 months from product delivery. On the products that have been fixed or replaced in accordance with what specified above, the above-mentioned warranty applies. The 12 month duration starts from the date of repair or replacement. In case of defects, lack of quality or in case of lack of compliance for the supplied products, with the exception of fraud or serious offence, Hydrocontrol s.p.a. only commits to repairing or replacing the faulty products, according to what specified above. This warranty replaces any other Supplier's warranty or liability established by the law. This warranty excludes any other liability contractual or extra-contractual by Hydrocontrol s.p.a. on the products supplied by Hydrocontrol (as a mere example: damage refund, loss of profit, product recall campaign, etc). Hydrocontrol s.p.a. has signed a product civil liability police, with a suitable maximum coverage.

Ownership retention

The products supplied by Hydrocontrol s.p.a. will be owned by the latter until Hydrocontrol receives the complete payment for the supplied goods.

Obligation confidentiality

Hydrocontrol s.p.a. commits to not disclosing the technical and commercial information it receives from the Customer, unless this information has already been publicly disclosed.

Patents

The Customer is not allowed to use the provided Products, or a part of them, their descriptions or drawings protected or not protected by Patent or registered trademark in order to design or make similar products, unless Hydrocontrol s.p.a. previously issues its written authorization. Should Hydrocontrol s.p.a. give its written authorization, all patents, trademarks, registered designs, copyrights and intellectual property rights related or connected to the Products provided by Hydrocontrol s.p.a. will stay Hydrocontrol's property. The Customer commits to respecting the highest confidentiality.

Applicable law and court of jurisdiction

Hydrocontrol s.p.a.'s supplies are regulated by these General Supply Conditions and, for anything not defined here, by the Italian law. Any controversy related, generated or connected to the supply of Products by Hydrocontrol s.p.a., where Hydrocontrol s.p.a. is involved, will be exclusively dealt with by the Court of Bologna.

Walvoil nel mondo - Walvoil worldwide
Sede principale, Filiali e Uffici di rappresentanza
Headquarters, Subsidiaries and Representative Offices

Walvoil S.p.A. - Headquarters

Via Adige, 13/D . 42124 Reggio Emilia . Italy
Phone +39 0522 932411 . info@walvoil.com - www.walvoil.com

Business Unit Hydrocontrol

Via San Giovanni, 481 . 40060 Osteria Grande
Castel S. Pietro Terme . Bologna . Italy
Phone +39 051 6959411

Galtech Site

Via Portella della Ginestra, 10 . 42025 Cavriago
Zona Industriale Corte Tegge . Reggio Emilia . Italy
Phone +39 0522 932411

AUSTRALASIA

Walvoil Fluid Power Australasia Pty Ltd

13 Vanessa Way . Delahey VIC 3037 . Melbourne . Australia
TEL. 0061 458 918 750 . australasia@walvoil.com

BRASILE . BRAZIL

Interpump Hydraulics Brasil Ltda - Walvoil Division

Gilberto de Zorzi, 525 . Forqueta Caxias do Sul (RS)
TEL. 0055 54 3223 2373 . infobrasil@walvoil.com

CANADA

Galtech Canada Inc.

3100, Jacob Jordan . Terrebonne . Qc J6X 4J6 . Canada
Phone +1 450 477 1076 Ext:225 . info@galtechcanada.com

CINA . CHINA

Walvoil Fluid Power (Shanghai) Company Limited

24, Lane 129, Dieqiao Road . Pu Dong . Kanqiao Industrial Zone Shanghai (201319)
TEL. 0086 21 60979800 . info@walvoil.com.cn

Guangzhou Bushi Hydraulic Technology Ltd

Shangwei Shaheshe, Yuehu Village . Xiancun, Xintang Town . Zengcheng City
511335 Guangzhou . Guangdong Province China
Phone +86 021 52380695 . fareast@hydrocontrol-inc.com

COREA DEL SUD . SOUTH KOREA

Walvoil Fluid Power Korea Ltd.

80-15, Oseongsandan 1Ro, Oseong-Myun, Pyungtaek, Kyungki . Korea 451-872
TEL. +82 31 682 6030 . info@walvoil.co.kr

FRANCIA . FRANCE

Walvoil Fluid Power France

362 rue de Bretagne . 44540 Vritz
TEL. 0033 2 41 94 41 06 . france@walvoil.com

INDIA

HC Hydraulic Technology(P) LTD

A5(B) Ngef Ancillary Indl. Estate . Whitefield Road
Mahadevpura (Po) . Bangalore 560048 . India
Phone +91 080 40454707 . info@hydrocontrol-india.com

Walvoil Fluid Power (India) PVT. LTD.

No 23, Doddanakundi Industrial Area Mahadevapura Post Behind Graphite India
Bangalore 560 048
TEL. 0091 80 41842900 . info@walvoil.co.in

U.S.A.

Hydrocontrol Inc.

1109, Technology Drive . Red Wing . MN 55066 . U.S.A.
Phone +1 651 212 6400 . usa@hydrocontrol-inc.com

Walvoil Fluid Power Corporation

4111 North Garnett Tulsa, OK 74116, USA
TEL. 001 918 858 7100 . info@walvoilfluidpower.com

1st edition D25.05

www.hydrocontrol-inc.com



D1WHEB08E

