

P75™ / P76™ SERVICE MANUAL

single
and multiple
oil hydraulic
pumps—motors

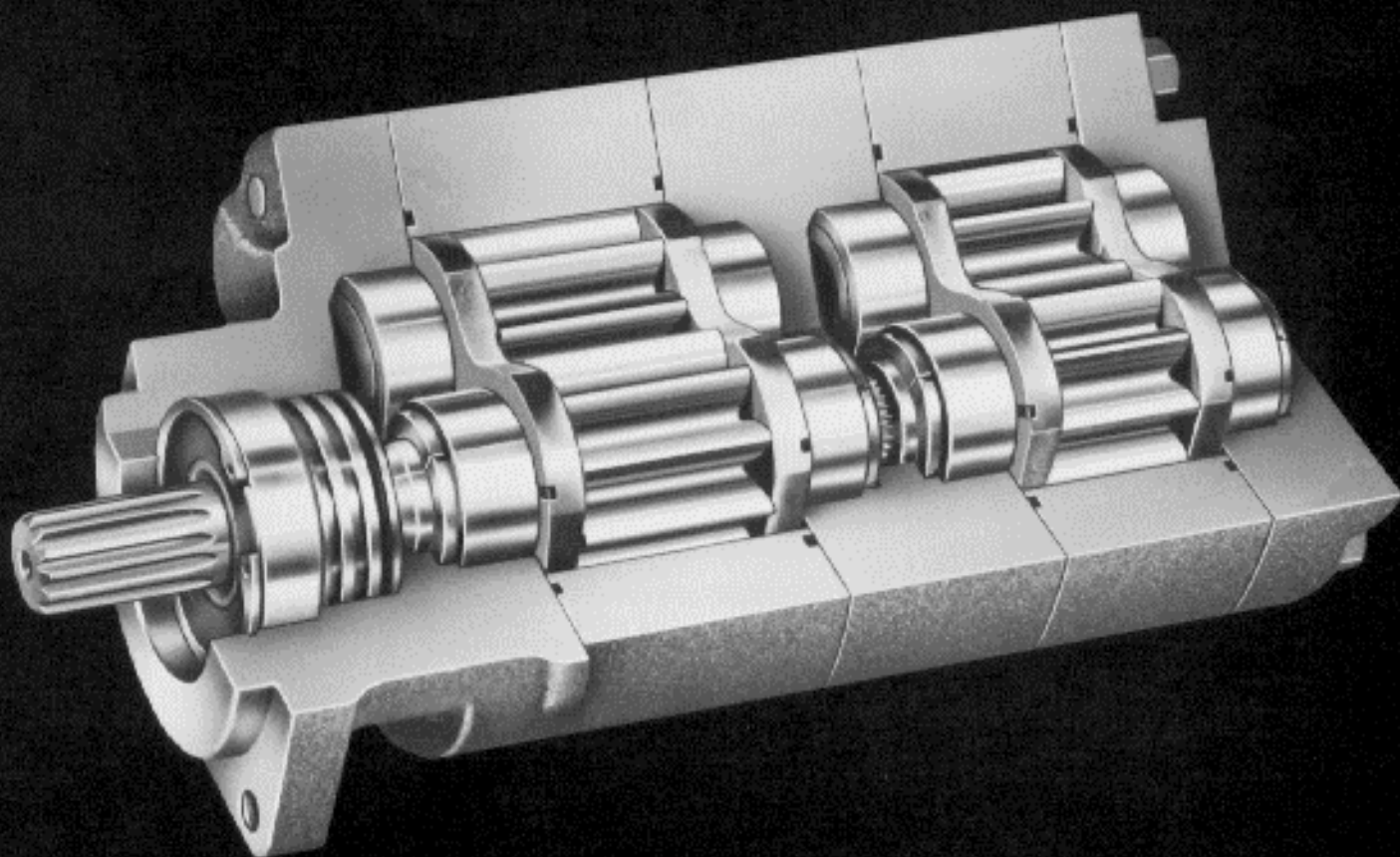

P75/P76

pump or motor service instructions

GENERAL INSTRUCTIONS

These service instructions will familiarize you with Commercial's single and multiple pumps and motors — their component parts — the relative position of each part — proper methods for assembly or disassembly of the units — care and use of these oil hydraulic power units — so that best performance and longer working life will result for your benefit.

To facilitate the repair of these units — and before any work is done — we suggest that you first read all of the steps used in disassembly and all of the steps used in building up the unit.

Dirt is the enemy of any hydraulic

system. The first requirement of good maintenance of hydraulic equipment is cleanliness. **MAKE SURE YOU DISASSEMBLE AND ASSEMBLE YOUR HYDRAULIC EQUIPMENT IN A CLEAN AREA.**

Our pictures show a Model P76. Notes in the text cover variations between this unit and the P75 model.

It is a good idea to check all replacement parts closely before installing to ensure that no damage occurred during shipment.

USE CAUTION IN GRIPPING ALL PARTS IN THE VISE TO AVOID DAMAGING MACHINED SURFACES.

A pump must be driven in the direction of rotation for which it was built; otherwise, pressure will blow the shaft seal. Check the exploded view below for proper direction of rotation.

COMMERCIAL'S REPLACEMENT PARTS

Commercial's replacement parts are of original equipment standards. For assured quality of material and workmanship, and for compatibility in assembly, **USE ONLY GENUINE PARTS FROM COMMERCIAL.**

It is a good idea to check all replacement parts closely before installing to ensure that no damage occurred during shipment.

EXPLODED VIEW AND PARTS LIST

1. Snap Ring
2. Spacer or Outboard Bearing
3. Seal Retainer
4. "O" Ring
5. Seal
6. Shaft End Cover
7. Check Assemblies or Plug
8. Ring Seals
9. Roller Bearings
10. Pocket Seals
11. Thrust Plates
12. Integral Drive Shaft and Gear Set
13. Gasket Seals
14. Gear Housing
- 14A. Dowel Pins (P76 only)
15. Connecting Shaft
16. Bearing Carrier
17. Matched Gear Set
18. Gear Housing
- 18A. Dowel Pins (P76 only)
19. Plug
20. Port End Cover
21. Name Plate
22. Drive Screws
23. Washers
24. Studs or Cap Screws
25. Nuts

Plug 7 in position B gives clockwise rotation.

Plug 7 in position A gives counterclockwise rotation.

Check valves in both positions give bi-directional rotation.

ITEMS SHADED APPLY TO MULTIPLE ASSEMBLIES ONLY.

© 1989 Commercial Intertech Corp.

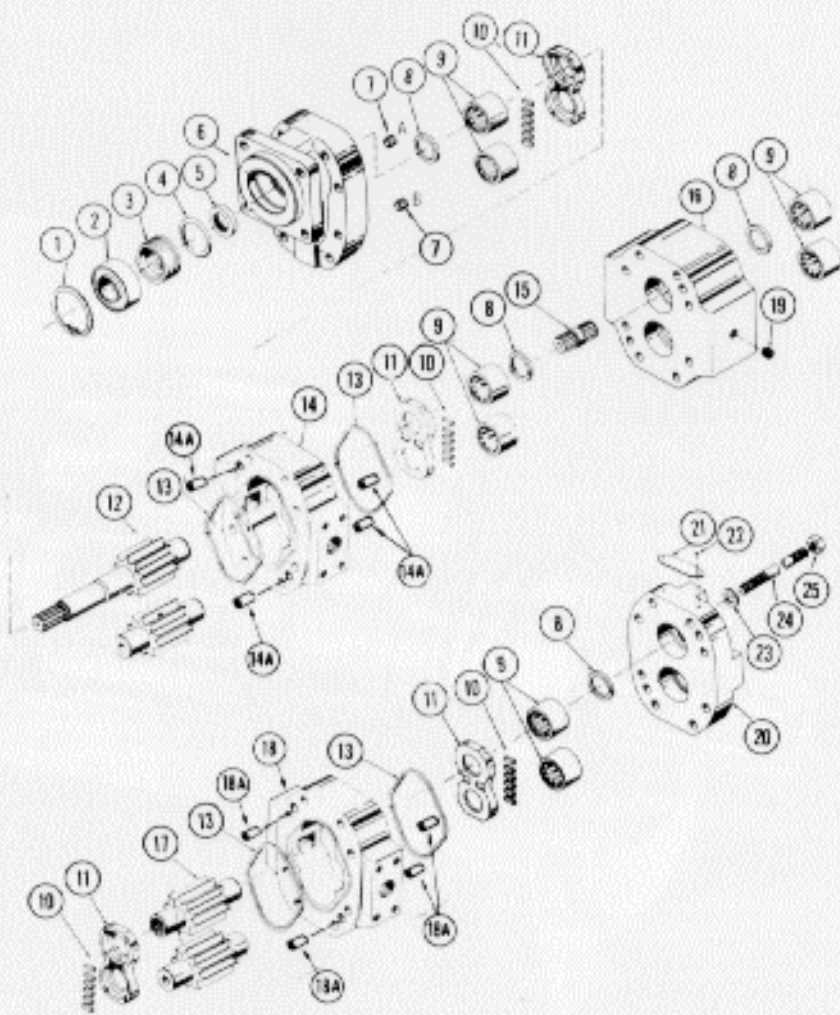

CAUTION:

1. If prying off sections becomes necessary, take extreme care not to mar or damage machined surfaces. Excessive force while prying can result in misalignment and seriously damage parts.

2. Do not force parts during assembly. Never use an iron hammer.

3. Gears are closely matched, therefore they must be kept together as sets when removed from a unit. Handle with care to avoid damage to the journals or teeth.

4. Never hammer roller bearings into bores, push them in place with an arbor press.

start disassembly here

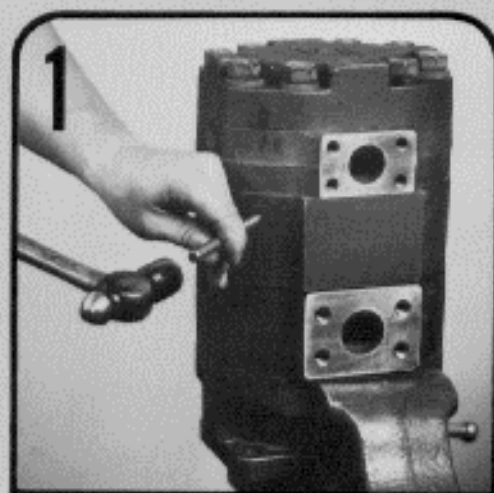

Place the pump in a vise with the drive shaft pointing down. Caution: DO NOT GRIP ON OR NEAR ANY MACHINED SURFACES DURING ASSEMBLY OR DISASSEMBLY. Index mark all sections with a punch. Be sure to align these marks when reassembling.



Remove the 8 cap screws or hex nuts and washers with a socket wrench.



Lift off the port end cover. If necessary to pry loose, be careful not to damage the machined surfaces. Dowel pins will remain in either port end cover or gear housing. Do not remove. If the thrust plate remains in the gear housing, it can be tapped out later with a wooden hammer handle. Be careful not to distort the thrust plate.



Lift the gear housing from the gears. If necessary to pry loose, take care not to damage machined surfaces.

disassembly, continued



5 Remove the drive and driven gears. Keep the gears together because they are a matched set. Examine and replace if necessary. See below.

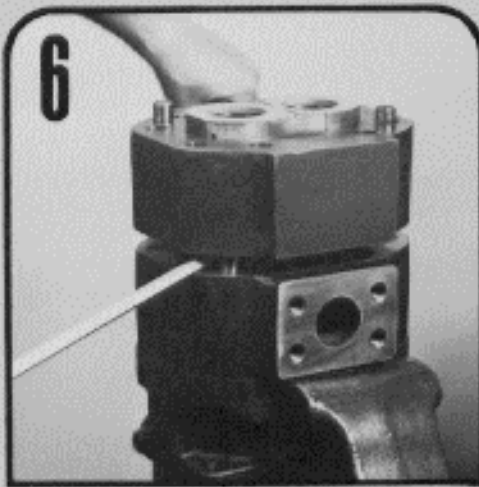

6 Lift or pry off the bearing carrier. Take care not to damage the machined surfaces.



Remove the connecting shaft.



11 Examine all roller bearings for wear and discoloration. If replacement is necessary, pull the bearings with a bearing puller. Any sign of wear or discoloration calls for replacement. Remove bearings with a bearing puller.

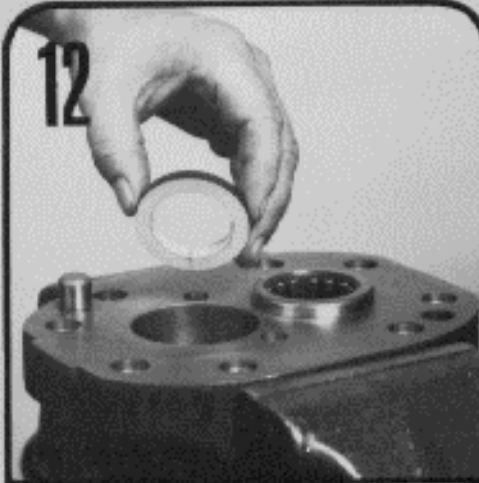

12 It is generally advisable to replace ring seals when rebuilding unit. To replace, remove the drive gear bearing with a bearing puller and remove ring seal from the bottom of bearing bore. Check all ring seal bores in unit for abnormal wear. If worn, replace those sections.



13 Grip the shaft end cover in the vise with the mounting face up. Remove the snap ring with snap ring pliers.

8

Lift or pry off the first section gear housing. Be careful not to damage machined surfaces. Remove thrust plate as described in step 3.

9

Remove the drive and driven gears. Keep the gears together because they are a matched set. Examine and replace if necessary. See pages 10 and 11.

10

Pry the thrust plate from the shaft end cover, port end cover, or bearing carrier with a screw driver or similar tool. Avoid distorting the thrust plate. Remove and discard all rubber pocket seals and gasket seals.

14

Remove the spacer or outboard bearing (pull the outboard bearing with a bearing puller).

15

Remove the seal retainer and seal with a light duty bearing puller. Remove and discard "O" ring.

16

Tap the seal from the seal retainer and discard. Clean seal bore with solvent to remove old sealant. If bore is scored, smooth with fine grade emery paper. It is generally advisable to replace the seal retainer.

start assembly here

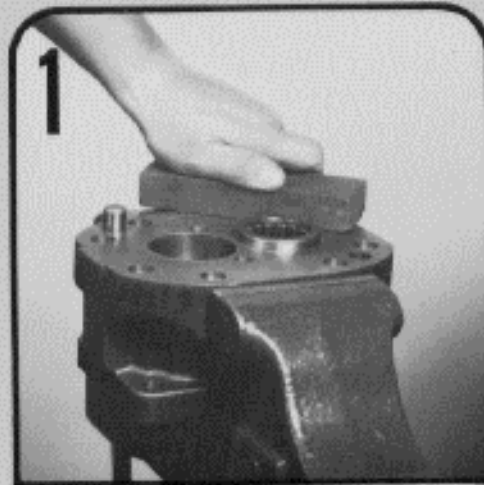

1 Stone off all cast machined surfaces with a medium grit carborundum stone (to remove any burrs as a result of disassembly). If bearings have been removed, deburr bearing bores. Rinse parts in a solvent. Air blast all parts and wipe with a clean, lintless cloth before starting reassembly.

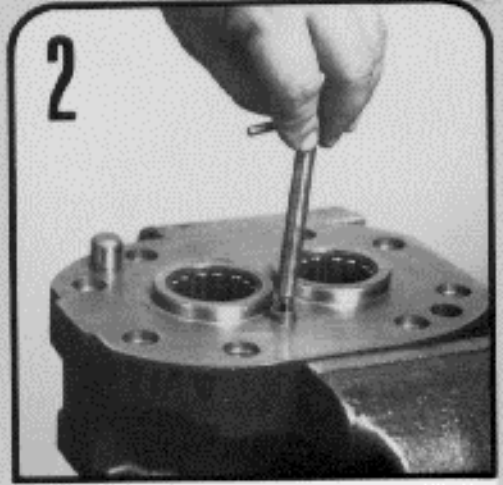

2 Grip the shaft end cover in the vise with the mounting face down. Examine the plug or 2 check valves, whichever is used, to be sure they are tightly in place. Replace only if parts are damaged or missing. Check valves can be removed with the special tool (see tool list). Screw in new valve with the tool until tight. Peen with a 1/8" steel ball to secure.



6 Cut 2 pocket seals 1-1/32" long from the pocket seal strip. Grease these pocket seals and insert into the middle slots in the thrust plate.



7 With the pocket seals down, place the thrust plate over the bearings. Tap thrust plate with a soft hammer to about 1/32" from the machined surface.

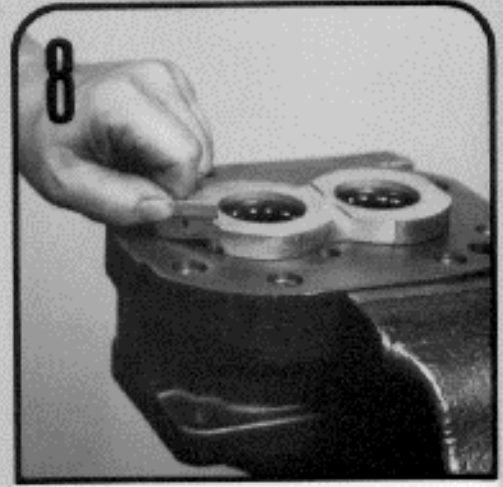

8 Cut 4 pocket seals approximately 7/16" long from the pocket seal strip. Insert one pocket seal into each of the slots in the thrust plate. Push each pocket seal all the way in so that they touch the roller bearings. Tap the thrust plate down firmly against the machined surface with a soft hammer. Use a sharp razor blade to trim exposed end of the pocket seal square and flush with the thrust plate.

3

ASSEMBLY STEPS 3, 4, 6, 7 AND 8 APPLY TO SHAFT END COVER, BEARING CARRIERS AND PORT END COVER.

If ring seals are being replaced, insert into bottom of drive gear bearing bore flat side down. The notch in the ring seal **MUST BE VISIBLE**. This is a check to be certain the notched side is next to the bearing.

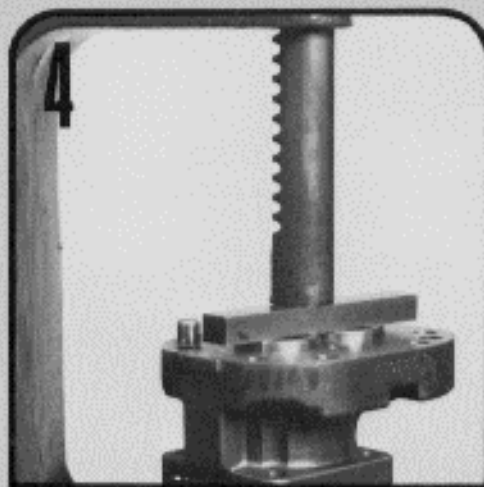
4

If any bearings have been removed from the shaft end cover, port end cover or bearing carrier, replace the bearings by pressing them into the bearing bore with an arbor press. Take care to avoid pressing on dowel pins.

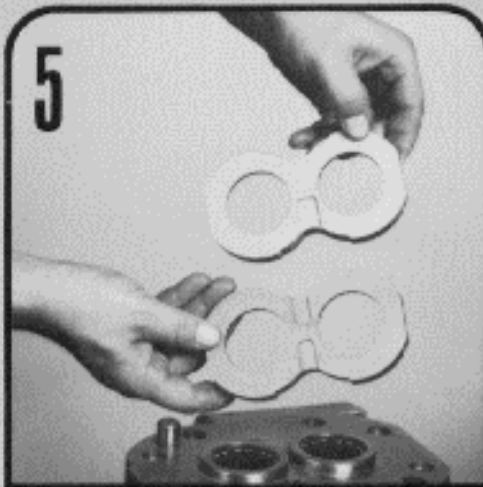
5

Check all thrust plates for wear. Replace if necessary (see below*). Note that the thrust plates for pumps and motors **can be different**. Pump thrust plates, that have a single relief pocket must be installed with this pocket on the high pressure side. Motor thrust plates are grooved on both sides. The relief groove on all the unidirectional thrust plates must be towards the high pressure (outlet) side of the pump.

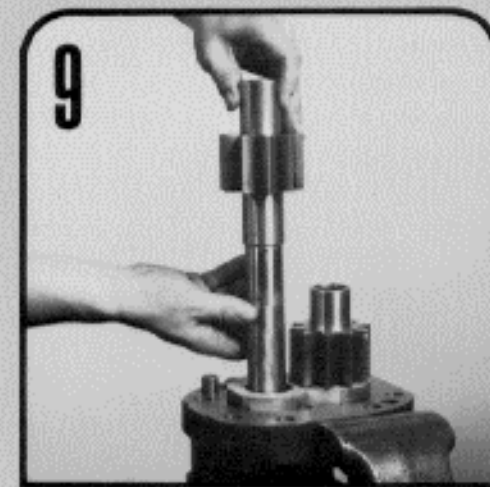
9

Insert the integral shaft and gear. Push down until the gear is tight against the thrust plate. Insert the matched driven gear.

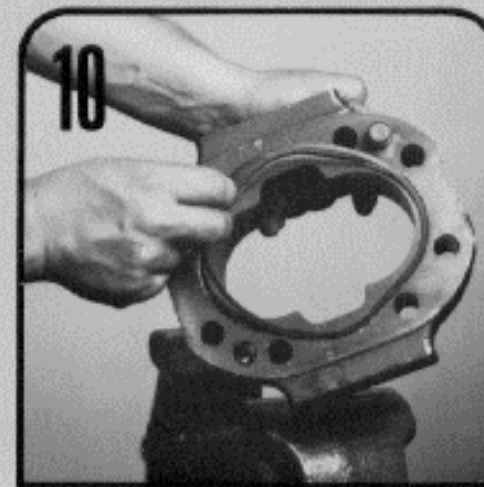
10

Grease the new gasket seals and insert them into the grooves in both sides of all gear housings.

11

Slide the first section gear housing over the gears and tap it with a soft hammer until it rests tightly against the shaft end cover. Be careful not to pinch the gasket seal. Squirt oil over the gears to provide initial lubrication when pump is started.

assembly, continued

12



Position the bearing carrier with thrust plates on the gear housing so that the roller bearings receive the journals of the drive and driven gears. Make sure that the index marks (See Step 1, Disassembly) are properly aligned. Tap the bearing carrier tight with a soft hammer.

FOR MULTIPLE ASSEMBLIES ONLY.

13



Insert the connecting shaft in the spline of the drive gear.

FOR MULTIPLE ASSEMBLIES ONLY.

14

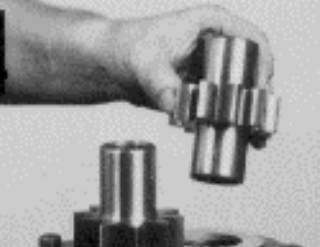

Insert the drive and driven gears of the second section in their respective bearings. Push down tightly against the thrust plate.

FOR MULTIPLE ASSEMBLIES ONLY.

18



Coat the outside of the seal with Permatex Aviation Form-A-Gasket 3D or equivalent. With the metal side of the seal down, press it into the seal retainer with a 2 1/4" diameter bar and an arbor press. Be careful not to damage the lip of the seal.

19



Grease and install the new "O" ring on the seal retainer. Lightly oil the installation sleeve and twist into the seal. Slide the sleeve over the drive shaft and push the seal retainer into place.

20

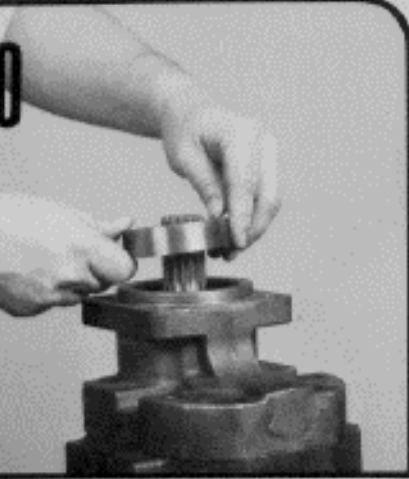

Drop in the spacer or outboard bearing. The outboard bearing may need to be lightly tapped into the bearing bore.

15



Slide the second section gear housing over the gears and tap it tight against the bearing carrier with a soft hammer. Be careful not to pinch the gasket seal. Squirt oil over the gears to provide initial lubrication when pump is started. Line up the dowels and the holes in the 2 castings. When parts are parallel, squeeze them together or gently tap alternately over the dowels with a plastic hammer until parts move smoothly together. **Do not force.** Insert dowel pins if required (P75 only). **FOR MULTIPLE ASSEMBLIES ONLY.**

16

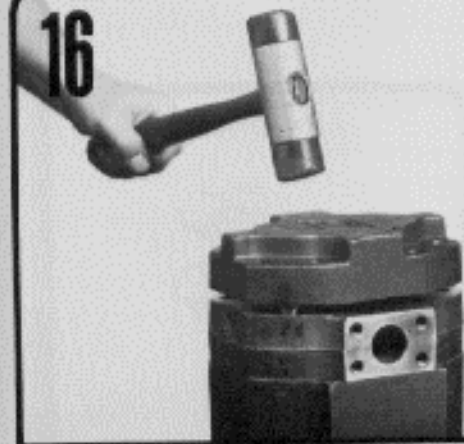

Place the port end cover over the gear journals and tap tightly against the gear housing. Be careful not to pinch the gasket seal.

17

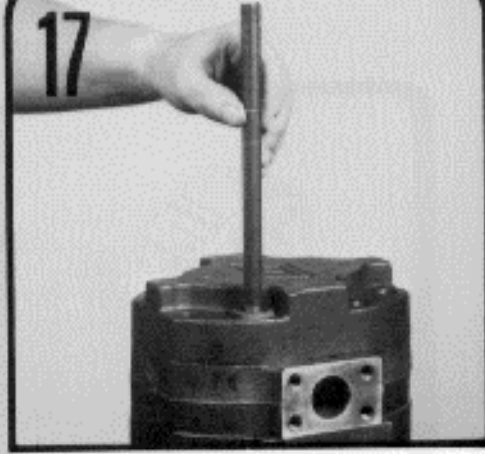

Thread the 8 fasteners (cap screws and washers, or studs and nuts) into the shaft end cover and snug up alternately or cross-corner. Rotate the drive shaft with a 6" wrench to make sure there is no binding in the pump.

After the fasteners are tight and you are sure there is no internal binding, torque the diagonally opposite fasteners to 200 ft. lbs. (2400 in. lb.)

21



Install the snap ring in the groove.

As a guide in answering the question, "How much wear is allowed before the part should be replaced?", we offer the following suggestions...

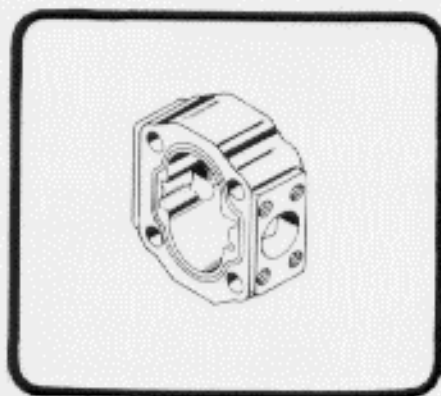

GEAR HOUSINGS:

Wear in excess of .005" cut-out necessitates replacement of the gear housing.

Place a straight-edge across bore. If you can slip a .005" feeler gage under the straight-edge in the cut-out area, replace the gear housing.

Pressure pushes the gears against the housing on the low pressure side. As the hubs and bearings wear, the cut-out becomes more pronounced. Excessive cut-out in a short period of time indicates excessive pressure or oil contamination. If the relief valve settings are within prescribed limits, check for shock pressures or tampering. Withdraw oil sample and check it and tank for dirt.

Where cut-out is moderate, .005" or less, gear housing is in good condition, and both ports are of the same size, housing may be flopped over and reused.

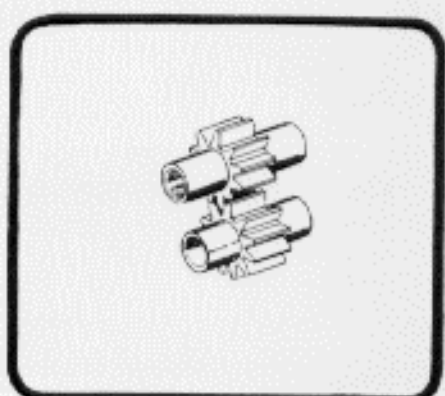

GEARS:

Any wear on gear hubs detectable by touch, or in excess of .002" necessitates replacement. Nicking, grooving, fretting of teeth surfaces or head discoloration also necessitates replacement. Scoring, grooving or burring of outside diameter of teeth generally means replacement is necessary unless damage is light and can be stoned off.

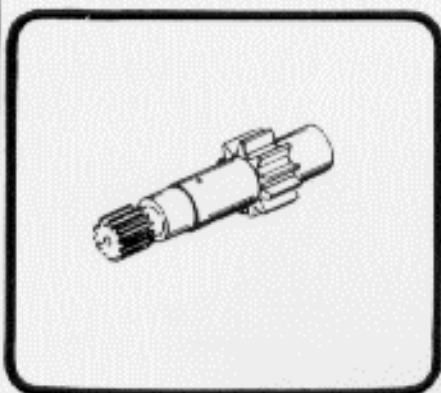

DRIVE SHAFTS:

Replace if there is any wear detectable by touch in the seal areas or at the drive coupling. .002" wear is the maximum allowable.

Wear in the shaft seal areas indicate oil contamination and shaft replacement is required. Wear or damage to splines, keys or keyways necessitates replacement.

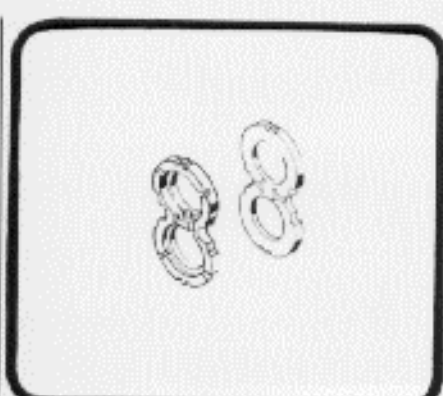

THRUST PLATES:

The thrust plates seal the gear section at the sides of the gears. Wear here will allow internal slippage, that is, oil will bypass within the pump. .002" maximum wear is allowable. Replace thrust plates if they are scored, eroded, pitted or discolored. Check center of thrust plates where the gears mesh. Erosion here indicates oil contamination. Pitted thrust plates indicate cavitation or oil aeration. Discolored thrust plates indicate overheating, probably insufficient oil.



DOWEL PINS:

If either the dowel pin or dowel hole is damaged, the pin or machined casting, or both, must be replaced.

If more than reasonable force is required to seat dowels, the cause may be poorly deburred or dirty parts; cocking of dowel in the hole; or improper pin-to-hole fit.



BEARINGS:

If gears are replaced, bearings must be replaced. Bearings should fit into bore with a light press fit. A neat hand fit is allowable. If bearings can fall out, bore may be oversize.



SEALS AND GASKETS:

Replace all rubber and polymer seals whenever disassembling pump. Include all "O" rings, pocket seals behind thrust plates, shaft seal and gasket seals.



CHECK VALVES:

Examine small check valves in shaft end cover to make sure they are intact and functioning. If there are no check valves here, make sure the high pressure side of the shaft end cover is plugged.

tool list

- Arbor Press
- Awl
- Bearing Puller (Owatonna Tool Co. MD-956 or equivalent)
- Clean Lintless Cloths
- Deburring Tool (an old file with the cutting teeth ground off)
- Machinist's Hammer
- Soft Rubber Hammer

Check valve tool is made from a 4" length of $\frac{1}{8}$ " drill rod. The drawing gives details for making this handy tool.

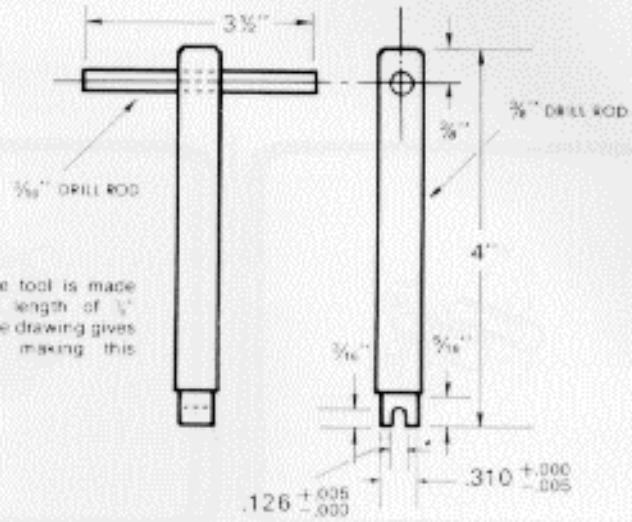

- Permatex Aviation Form-A-Gasket No. 3D Sealant or equivalent
- Medium Grit Carborundum Stone
- Oil and Grease
- Snap Ring Pliers
- Center Punch
- Sharp Razor Blade
- Scale (1/32" or 1/64" graduations)
- 2 Large Screwdrivers/Pry Bars
- Torque Wrench
- Vise with 6" Minimum Open Spread
- Light Duty Bearing Puller for Seal Retainer
- Special Steel Sleeve or Cardboard Sleeve
- Steel Ball

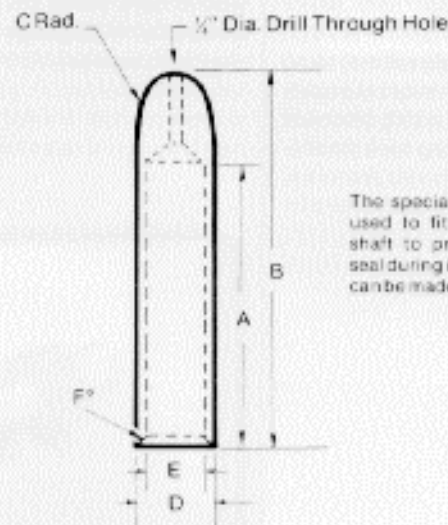

The special steel sleeve is used to fit over the drive shaft to protect the shaft seal during installation. This can be made from bar stock.

	A	B	C Radius	D Dia.	E Dia.	F° Chamfer
P75/75	4 1/4"	5 1/2"	1/4"	1.379 ^{+ .000} - .002	1.259 ^{+ .002} - .000	30°

All External surfaces must be free of scratches and burrs.

Lubrication and oil recommendations

All parts, with the exception of the outboard bearing, are lubricated by the hydraulic oil in the circuit. Particular attention must be paid to keep the oil in the system clean. Whenever there is a pump or motor failure, and there is reason to feel that metal particles may be in the system, the oil must be drained, the entire system flushed clean, and any filter screens thoroughly cleaned or replaced. New oil should be supplied for the entire system. Oil suitable and recommended for use in circuits involving Commercial's pumps and motors should meet the following specifications:

- Viscosity:**
- 50 SSU minimum @ operating temperature
 - 7500 SSU maximum @ starting temperature
 - 150 to 225 SSU @ 100° F. (37.8° C.) (generally)
 - 44 to 48 SSU @ 210° F. (98.9° C.) (generally)

Oil Grade	Approximate SSU at . . .	
	100° F. (37.8° C.)	210° F. (98.9° C.)
SAE 10	150	43
SAE 20	330	51

Viscosity Index: 90 minimum

Aniline Point: +175°F (80°C) minimum

Recommended Additives: Foam Depressant
Rust and Oxidation Inhibitors

Other Desirable Characteristics:

- Stability of physical and chemical characteristics.
- High demulsibility (low emulsibility) for separation of water, air, and contaminants.
- Resistant to the formation of gums, sludges, acids, tars, and varnishes.
- High lubricity and film strength.

General Recommendations:

A good quality hydraulic oil with the characteristics listed above is essential to satisfactory performance and long life of any hydraulic system.

Oil should be changed on regular schedules in accordance with the manufacturer's recommendations, and the system periodically flushed.

Oil temperature in reservoir must not exceed 200° F., (93.3° C.) with a maximum operating temperature of 180° F. (82.2° C.) recommended. Higher temperatures will result in rapid oil deterioration.

Reservoir capacity should equal in gallons the pump output in gpm or the total gpm of all pumps where there is more than one in the system.

Oil poured into the reservoir should pass through a 100 mesh screen. Pour only clean oil from clean containers into the reservoir. A 100 mesh screen may be used in the suction line leading to the pump. A suction filter should be of sufficient size to handle twice the pump capacity. It must be cleaned and checked regularly to avoid damage due to contamination and cavitation.

Normal Temperatures:

0° F. (-18° C.) to 100° F. (37.5° C.) Ambient
100° F. (37.8° C.) to 180° F. (82.2° C.) System

Be sure your oil is recommended for the temperatures you expect to encounter.

Cold Weather Operation

Oils for use in cold weather should have a viscosity not exceeding 7500 SSU at the minimum start-up temperature. A pour point of at least 20° F (-6.7° C) below start-up temperature is recommended. Start-up procedures should allow for a gradual warm-up until the oil reaches a reasonably fluid state.

The Use of Other Oils

- Automatic Transmission Fluid (ATF): General experience here has been satisfactory, however, ATF oils are sometimes too expensive for normal use in hydraulic systems.
- Diesel Fuel or Kerosene (Coal Oil): Sometimes used as dilutants for cold weather operations but are not recommended as they are not sufficiently refined products.
- Fire Resistant Fluids: Of the several different types, only the inverted emulsion types may be used without changing to special seal, packing, gasket, hose, etc., compositions. Their use may materially reduce pump life. Experience indicates that the use of FR fluids can be disastrous unless certain precautions are followed. **DO NOT USE ANY FIRE RESISTANT FLUIDS OR NON-PETROLEUM OILS WITHOUT CONSULTING OUR TECHNICAL SERVICE DEPARTMENT.**
- These suggestions are intended as a guide only. **OBTAIN YOUR FINAL OIL RECOMMENDATIONS FROM YOUR OIL SUPPLIER.**

recommended start-up procedure for new or rebuilt pump or motor

Before installing a new or rebuilt pump or motor, back off the main relief valve until the spring tension on the adjusting screw is relieved. This will avoid the possibility of immediate damage to the replacement unit in the event that the relief valve setting had been increased beyond the recommended operating pressure.

Before connecting any lines to the pump or motor, fill all ports with clean oil to provide initial lubrication. This is particularly important where the unit is located above the oil reservoir.

After connecting the lines and mounting the replacement unit, operate the pump or motor at least two minutes at zero pressure at lowest possible rpm. During this break-in period, the unit should run free and not develop an excessive amount of heat. If the unit operates properly, speed and pressure can then be increased to normal operating settings.

Reset the main relief valve to its proper setting while the pump is running at maximum operating engine (motor) speed for the vehicle.

**ALWAYS USE AN ACCURATE GAUGE WHEN
ADJUSTING THE RELIEF VALVE PRESSURE SETTING.**

recommended test procedure

Be sure there is an adequate supply of oil for the pump, at least one gallon of oil for each gpm of pump capacity.

If one section of a tandem pump is being tested, make sure that all other sections not being tested are adequately supplied with oil. If any of the other sections run dry, or if plugs are left in ports, serious and permanent damage will result.

The oil should be a good quality hydraulic oil rated at 150 SSU at 100°F, (37.8°C) with the oil temperature held at 120°F (48.9°C) plus or minus 5°F (-20.6°C). (Test procedures are described in detail in SAE handbooks; see Hydraulic Power Pump Test Procedure, SAE J745c.)

The feed line must be of adequate size with no more than 5" mercury vacuum (.17 kgs/cm²) adjacent to the pump inlet. As a rule, the feed line must provide a feed flow velocity not in excess of 8 feet per second (243.84 cms/sec).

Feeding hot oil into a cold pump may cause the pump to seize. Jog the pump by momentarily starting the driving engine or motor to gradually equalize pump and oil temperatures.

Run the pump at least two minutes at zero pressure and moderate speed (not over 1500 rpm). If the pump becomes excessively hot, shut down immediately and locate the problem source.

Gradually increase pump pressure to the desired test level; this should take approximately 5 minutes.

Delivery should run close to rated catalog performance figures which are averaged from testing several pumps. A 5% lower reading may be used as a rated minimum if new or relatively new parts have been used. When rebuilding with parts from the original pump which may be satisfactory for re-use, a 10% or 15% lower reading may be used. This depends on the performance expected from the equipment; one's own experience will prove the best guide.

Many repairmen measure the output at normal operating speed and at zero pressure, then again at 1000 psi/70 bar (or the operating pressure of the equipment) and allow a volume decrease approximating the listing below. This is a suggested reference only which makes allowance for re-used parts.

GPM (l/min) DELIVERY

at 1800 rpm 100 psi	GPM DROP OFF AT...			
	1000 psi/70 bar	1500 psi/105 bar	2000 psi/140 bar	2500 psi/175 bar
5 — 14 (18.9 — 53.0)	2 to 3 7.6 to 11.4	2½ to 3½ 9.5 to 13.2	3 to 4 11.4 to 15.1	5 to 6 18.9 to 22.7
15 — 25 (56.6 — 94.6)	2½ to 3½ 9.5 to 13.2	3 to 4 11.4 to 15.1	3½ to 5 13.2 to 18.9	5 to 7 18.9 to 26.5
26 — 50 (98.4 — 189.3)	3 to 4 11.4 to 15.1	4 to 5 15.1 to 18.9	4 to 6 15.1 to 22.7	6 to 9 22.7 to 34.1

At test speeds other than 1800 rpm, gpm delivery will vary almost proportionately, but the same (drop-off) figures should be used.

Be sure to run the pump in the direction for which it was designed and built. Driving pump in the wrong direction will build up pressure behind shaft seal, damaging it and necessitating replacement.

Since it is rarely feasible to test motors on dynamometers, the practical procedure is to test them as pumps, running complete testing procedures in each direction.

After completing testing procedures, pump is ready for installation and immediate use on equipment. Again, remember that to prevent seizure, hot oil must not be fed into a cold pump.



Commercial Intertech

Global Headquarters are located at 1775 Logan Avenue, Youngstown, Ohio 44501-0239 • U.S.A.

...we're putting technology to work worldwide

District sales offices:

ACTON, ON L7J 2M6 CANADA

Commercial Intertech Ltd.
6 Commerce Crescent, P.O. Box 450
Phone: (519) 853-0770
Facsimile: (519) 853-3837

BEAVERTON, OR 97005-5464

6700 S.W. 105th, Suite 311R
Phone: (503) 643-0195
Facsimile: (503) 641-4360

BENTON, AR 72018-0647

20138 I-30
P.O. Box 647
Phone: (501) 794-0334
Facsimile: (501) 794-0732

CHICAGO, IL 60638-4911

6501 West 65th Street
Phone: (708) 594-1161
Facsimile: (708) 458-2463

DALLAS, TX 75234-7311

2655 Villa Creek Drive, Suite 299
Phone: (214) 241-1975
Facsimile: (214) 241-2128

HICKSVILLE, OH 43526

373 Meuse Argonne
Phone: (419) 542-6611
Facsimile: (419) 542-8671

KINGS MOUNTAIN, NC 28086-0219

101 Canterbury Road
P.O. Box 219
Phone: (704) 739-8232
Facsimile: (704) 739-2269

ORANGE, CA 92667-5597

341 West Collins Avenue
Phone: (714) 639-4630
Facsimile: (714) 532-4126

YOUNGSTOWN, OH 44501-0239

1775 Logan Avenue
P.O. Box 239
Phone: (216) 746-8011 • Telex: 433-2153
Facsimile: (214) 746-1148

Subsidiary companies:

MINNEAPOLIS, MN 55428-4998

Oilayne Division
Commercial Intertech Corp.
4301 Quebec Avenue, North
Phone: (612) 533-1600
Facsimile: (612) 533-0082

MINNEAPOLIS, MN 55434

Cylinder City, Inc.
1532 93rd Lane, N.E.
P.O. Box 34220
Phone: (612) 780-2550
Facsimile: (612) 780-2565

**PORT MELBOURNE, VICTORIA 3207,
AUSTRALIA**

Commercial Hydraulics Pty., Ltd.
265 Ingles Street, P.O. Box 191
Phone: 61-3-646-2017 • Telex: 34377
Facsimile: 61-3- 646-2257

SAO PAULO, BRAZIL

Commercial Intertech do Brasil Ltda.
Rua AMF do Brazil, 251
18120 - Mairinque
Sao Paulo, Brazil
Phone: 55-11-428-2122
Facsimile: 55-11-428-2099

GLOUCESTER GL3 4XE, ENGLAND

Commercial Hydraulics Gloucester Ltd.
Gloucester Trading Estate, Hucclecote
Phone: 44-452-618-666
Telex: 43651 CHCLOS G
Facsimile: 44-452-371-106

GRANTHAM NG31 9SJ, ENGLAND

Commercial Hydraulics Kontak Ltd.
Belton Park, Londonthorpe Rd.
Grantham, Lincolnshire
Phone: 44-476-64105
Facsimile: 44-476-66462 Telex: 37170

LIVERPOOL L9 7BW, ENGLAND

Commercial Hydraulics Liverpool Ltd.
Long Lane, Fazakerley
Phone: 44-51-525-5933
Telex: 629-561 COMLIV G
Facsimile: 44-51-523-4198

WARWICK CV34 6TU, ENGLAND

Commercial Hydraulics Keelavite Ltd.
Tachbrook Park Drive, Tachbrook Park
Phone: 0926-889-000
Facsimile: 0926-889-172

FRANCE

Commercial Hydraulics Astron S.A.R.L.
BP 73,
20, rue Pierre Mendes - France, Torcy
77202 Marne LaVallée - Cedex 01
Phone: 33-1-6462-1100
Telex: 693-737 F
Facsimile: 33-1-6462-1093

HAMBURG 90, GERMANY

Commercial Intertech GmbH
Winsener Strasse 69, D-2100
Phone: 49-40-763-8399
Facsimile: 49-40-764-3964

LAMADELAINE, LUXEMBOURG

Commercial Intertech S.A.
39, rue de la Gare, L-4873
Phone: 352-503-7271
Telex: 848-3367
Facsimile: 352-501-359

STOCKHOLM, SWEDEN

Commercial Hydraulics AB
Veddestavagen 24, S-175-62 JARFALLA
Phone: 46-8-795-5660
Facsimile: 46-8-795-6621

VERONA, ITALY

Commercial Hydraulics SRI
Via dell'Agricoltura 1/A
Phone: 39-45-676-7250
Telex: 843-351-893
Facsimile: 39-045-676-7229

Designers and Manufacturers of Fluid Power Components, Worldwide; Pressed Metal Products, North America;
Filtration and Separation Products, Worldwide; and Pre-Engineered Buildings; Europe.